



**Skill India**  
कौशल भारत - कुशल भारत



# Facilitator Guide



Sector  
Telecom

Sub-Sector  
Handset

Occupation  
Communication Electronics

Reference ID: TEL/Q2501, Version 4.0 NSQF Level: 4

**Telecom  
Surface Mount  
Technology  
(SMT)  
Technician**



Click/Scan this QR code to access e-Book

**This book is sponsored by**

**Telecom Sector Skill Council of India**

Estel House, 3rd Floor, Plot No:- 126, Sector 44

Gurugram, Haryana 122003

Phone: 0124-2222222

Email: [tssc@tsscindia.com](mailto:tssc@tsscindia.com)

Web: [www.tsscindia.com](http://www.tsscindia.com)

All Rights Reserved © 2022  
First Edition, December 2022

Printed in India

**Copyright © 2022**

**Under Creative Commons License: CC-BY -SA**

**Attribution-ShareAlike: CC BY-SA**



### **Disclaimer**

The information contained herein has been obtained from sources reliable to Telecom Sector Skill Council of India. Telecom Sector Skill Council of India disclaims all warranties to the accuracy, completeness or adequacy of such information. Telecom Sector Skill Council of India shall have no liability for errors, omissions, or inadequacies, in the information contained herein, or for interpretations thereof. Every effort has been made to trace the owners of the copyright material included in the book. The publishers would be grateful for any omissions brought to their notice for acknowledgements in future editions of the book. No entity in Telecom Sector Skill Council of India shall be responsible for any loss whatsoever, sustained by any person who relies on this material





**Shri Narendra Modi**  
Prime Minister of India

“ **Skilling is building a better India.  
If we have to move India towards  
development then Skill Development  
should be our mission.** ”

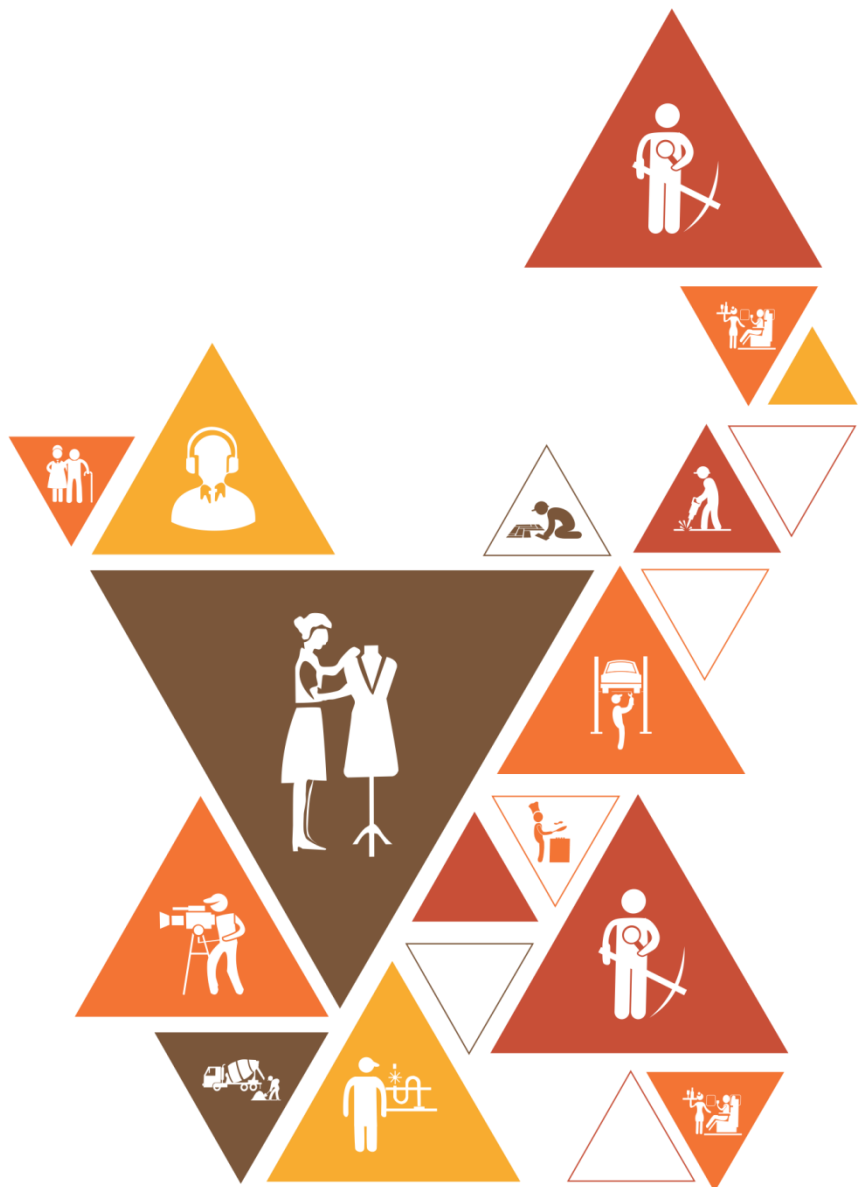

## Acknowledgements

Telecom Sector Skill Council (TSSC) would like to thank all the individuals and institutions who contributed in various ways towards the preparation of this facilitator guide. The facilitator guide could not have been completed without their active contribution. Special gratitude is extended to those who collaborated during the preparation of the different modules in the facilitator guide. Wholehearted appreciation is also extended to all who provided peer review for these modules.

The preparation of this guide would not have been possible without the Telecom Industry's support. Industry feedback has been extremely beneficial since inception to conclusion and it is with their guidance that we have tried to bridge the existing skill gaps in the industry. This facilitator guide is dedicated to the aspiring youth, who desire to achieve special skills which will be a lifelong asset for their future endeavours.

## About this Guide

The facilitator guide (FG) for Optical Fibre Technician is primarily designed to facilitate skill development and training of people, who want to become professional Optical Fibre Technicians in the industry. The Facilitator Guide is aligned to the Qualification Pack (QP) and the National Occupational Standards (NOS) as drafted by the Telecom Sector Skill Council of India (TSSCI) and ratified by National Skill Development Corporation (NSDC).

It includes the following National Occupational Standards (NOSs):

1. TEL/N2503: Screen printing of Telecom Boards
2. TEL/N2504: Component Placement on Telecom Boards
3. TEL/N2505: Re-flow soldering on Telecom Boards
4. TEL/N2502: Cleaning and Inspection of Telecom Boards
5. TEL/N9101: Organize work and resources as per health and safety standards
6. TEL/N9102: Interact effectively with team members and customers
7. DGT/VSQ/N0102: Employability Skills (60 Hours)

Post this training, the participants will be able to perform tasks as professional Optical Fibre Technician. We hope that this Facilitator Guide provides a sound learning support to our young friends to build a lucrative career in the telecom industry.

## Symbols Used



Ask



Demonstrate



Facilitation Notes



Learning Outcomes



Notes



Objectives



Practical



Team Activity



Do



Explain



Say



Resources



Activity



Summary



Role Play



Example

## Table of Contents

S.No.	Modules and Units	Page No.
1.	<b>Introduction to role and responsibilities of Telecom Surface Mount Technology (SMT) Technician</b>	1
	Unit 1.1 – Fundamentals of Electronics	3
	Unit 1.2 – Basic Functionality of Common Electronic Components	11
	Unit 1.3 – Introduction to Printed Circuit Boards (PCB)	15
	Unit 1.4 – PCB Designing Concepts	22
2.	<b>Screen Printing of Telecom Boards (TEL/N2503)</b>	25
	Unit 2.1 - Screen Printing Process	45
	Unit 2.2 - Pre-baking of Board	47
	Unit 2.3 - Screen-Printing Machines	57
	Unit 2.4 - Inspection of Solder Paste Printing	
3.	<b>Component Placement on Telecom Boards (TEL/N2504)</b>	66
	Unit 3.1 - Components Pick and Place Operations	68
	Unit 3.2 - Pick and Place Operations	72
	Unit 3.3 - Loading of Component	79
4.	<b>Reflow Soldering on Telecom Boards (TEL/N2505)</b>	89
	Unit 4.1 - Reflow Soldering	91
	Unit 4.2 - Operation of Reflow Machine	95
5.	<b>Cleaning and Inspection of Telecom Boards (TEL/N2502)</b>	99
	Unit 5.1 - Cleaning of PCBs	101
	Unit 5.2 - Inspection of PCBs	1
6.	<b>Industrial Education</b>	1
	Unit 6.1 – Workplace Communication	112
	Unit 6.2 – Maintenance Procedure and QC Tools	116
	Unit 6.3 – Standard Operating Procedures	



<b>7.</b>	<b>Organize Resources and Work Effectively and Safely (TEL/N9101)</b>	<b>122</b>
	Unit 7.1 – Workplace Health and Safety	122
	Unit 7.2 – Different Types of Health Hazards	124
	Unit 7.3 – Importance of Safe working Practices	157
	Unit 7.4 – Reporting Safety Hazards	168
	Unit 7.5 – Waste Management	187
	Unit 7.6 – Organization’s Focus on Greening of Jobs	
<b>8.</b>	<b>Communication and Interpersonal Skills (TEL/N9102)</b>	<b>187</b>
	Unit 8.1 - Interaction with supervisors, peers, customers and differently abled person	203
	Unit 8.2 – Explain the importance of developing sensitivity towards disabled persons	227

## 9. Annexure

Annexure I: Training Delivery Plan

Annexure II: Assessment Criteria

Annexure III: List of QR codes in PHB

<https://www.skillindiadigital.gov.in/content/list>









**Skill India**  
कौशल भारत - कुशल भारत



सत्यमेव जयते  
GOVERNMENT OF INDIA  
MINISTRY OF SKILL DEVELOPMENT  
& ENTREPRENEURSHIP



N · S · D · C  
National  
Skill Development  
Corporation

Transforming the skill landscape



# Introduction to the role and responsibilities of Telecom Surface Mount Technology (SMT) Technician

Unit 1.1 – Fundamentals of Electronics

Unit 1.2 – Basic Functionality of Common Electronic Components

Unit 1.3 – Introduction to Printed Circuit Boards (PCB)

Unit 1.4 – PCB Designing Concepts

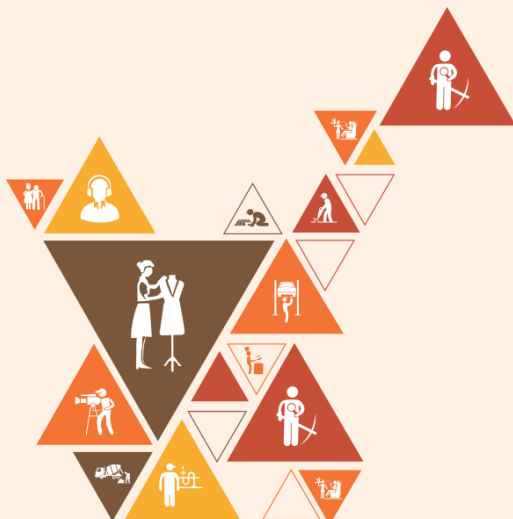

## Key Learning Outcomes

At the end of this module, you will be able to:

1. Identify the basic electrical quantities
2. List the factors affecting the resistance of an element
3. Define Ohm's law
4. Differentiate between series connection and parallel connection
5. List the types of electronic components
6. Identify the applications of diodes and transistors
7. Demonstrate the functions of different logic gates
8. Assess the applications of transmitters and receivers
9. Distinguish between different types of switches
10. Identify different power supplies
11. Classify different types of amplifiers
12. List the applications of multiplexers and demultiplexers
13. Identify the various parts of a PCB
14. Differentiate between the different layers of a PCB
15. List the three types of PCB
16. Analyse the performance requirements of a PCB
17. List the steps of designing a PCB
18. Identify the inspection checks to be performed
19. Execute the cleaning of boards before pattern transfer
20. List the standards published by IPC

## UNIT 1.1: Fundamentals of Electronics

### Unit Objectives



**At the end of this unit, students will be able to:**

1. Identify the basic electrical quantities
2. List the factors affecting the resistance of an element
3. Define Ohm's law
4. Differentiate between series connection and parallel connection

### Notes



- You could ask the students what they know about fundamentals of Electronics
- Give students some time to think about how the telecom industry in India operates
- Give students some time to think about various Active & Passive components including Resistors, capacitors, inductors and colour coding of capacitors and resistors
- Set the context and describe the industry trends in telecom and significance of Electronics

## 1.1: Charge

### Say



- Before we learn the skills, which will help us, do our jobs really well. It is essential that we understand the telecom broad band market and the history of growth in India.
- Liberalization in the 1990s resulted in an improved business climate and an increased investment across the country
- India has more than 700 million subscribers with a tele-density of more than 60%
- It still is a high potential sector and hence requires more attention and policy frame-work to address challenges

### Do



- Refer to the relevant slides in the presentation and share it with the participants
- Share with the participants about telecom Industry Growth – benefits accrued
- Share with the participants about Indian telecom history
- Share with the participants about Indian telecom history - growth
- Share with the participants about Indian Telecom Growth – urban & rural
- Share with the participants about Indian Telecom – drivers of affordability
- Share with the participants about Indian Telecom model
- Share with the participants about key M & A acquisitions by Indian firms
- Share with the participants about Indian Telecom Regulatory Authority - TRAI

### Notes



An electric charge is the property of matter where, in its atoms, the number of electrons is either more or less than the number of protons. Electrons bear a negative charge while the protons bear a positive charge. If the matter has more protons than electrons, it is positively charged and if the number of electrons exceeds the number of protons, it is negatively charged.

The electric charge is represented by Q and is measured in Coulomb (C).

1 C of charge =  $1 / 1.6 \times 10^{-19}$  or  $6.24 \times 10^{18}$  electrons.

## 1.1.2: Electric Current

### Say

Electric current can be defined as the flow of electric charge in the form of free electrons. The number of free electrons that passes a particular point of a circuit per second is the measure of the electric current in it. Hence, the amount of current in a circuit is defined by the flow of charge per unit second.

The current is measured in Amperes in International System of Units (SI) and is denoted with the symbol A. Constant current is denoted by the symbol I. The value of the current is 1 A when the electric charge flows at the rate of 1 coulomb per second, that is  $6.24 \times 10^{18}$  electrons passing a given point per second.

Mathematically, the relationship between electric current (I) and charge (Q) is defined as:

$$I \text{ (amperes)} = Q \text{ (coulombs)} / t \text{ (seconds)}$$

Where, I denotes average current flowing; Q denotes total charge flowing across a fixed point and t denotes the time that is taken for passing the fixed point.

Conventionally, the current flows from the positive end to the negative end and in the direction of the movement of the positive charge. Electrons flow from the negative end to the positive end, in the opposite direction of the current flow. The direction of the positive current flow in a circuit is represented by an arrow.

### Ask

- Ask the students about the role and responsibilities of a SMT technician
- Ask the students to explain the job responsibilities of a SMT technician

### Notes

- Divide the students within groups and assign “companies” to students
- Give each group to prepare presentation on the assigned companies for around 15 minutes
- Give 5 minutes to each group for presentation

### Do

- Team 1 to list down on a flip chart - What do you understand by the role of ‘SMT Technician’?
- Team 2 to list down on a flip chart - What do the contractors understand by the role of ‘SMT technician’?
- Team 3 to list down on a flip chart - What your ‘Customers’ expect from you as – SMT technician?
- Team 4 to list down on a flip chart - What does your ‘Supervisor’ expect from you as – SMT fibre technician?

- Ensure participation and also facilitate the activity within each team
- Facilitate the discussion and avoid arguments
- Summarise with the help of relevant presentation slide. Refer to page 4 of the participant’s manual

### 1.1.3: Voltage or Potential Difference

Say



- Before we move any further let us understand the difference between Voltage or Potential difference
- Let us also understand the term 'volts'

Do



- Share with the participants voltage or potential difference is the difference between the electric potential or charge of two points thus, the potential difference between two points is determined by the work done in joules to move charge of coulombs from one point to the other voltage is measured in volts in SI system and is given as

volts

oules

coulombs

Notes



- Ensure participation and also facilitate the activity amongst the students
- Facilitate the discussion and avoid arguments
- Summarise with the help of relevant presentation slides. Refer to page 5 of the participant's hand book
- Conduct a quick quiz in order to test the participants understanding about the public switched telephone network
- Move on to the next section which is about transmission media

## 1.1.4: Resistance

### Ask



- Ask the students about their understanding of the resistance?
- Ask the students to list the various transmission media they know?

### Say



Besides being influenced by the voltage that propels it around, the current in an electrical circuit also depends on the resistance of the components, wires and connections of the circuit. Resistance (R) refers to the ability of the circuit components to oppose the electron flow (flow of current) in the circuit, thereby necessitating the supply of a greater voltage to the circuit so that current can flow again. Resistance opposes the flow of current.

The amount of resistance that different circuit elements put up against the current flow varies. The circuit elements with low resistance are termed as 'good conductors', the ones with high resistance are termed as 'bad conductors' or 'insulators' and the rest are in between these two categories. The unit of resistance is Ohm. The resistance of any material which has a uniform cross-sectional area, A and length, l, can be represented in a mathematical form as:

$$R = \rho * l / A$$

where,  $\rho$  is the resistivity of the material in ohm-meters.

### Do



- Share with the participants the various factors affecting the resistance of an element
- Share with the participants the benefit of the various media of transmission that have been listed

### Notes



- Facilitate the discussion and avoid arguments
- Summarise with the help of relevant material. Refer to the relevant sections on page and of the participant's hand book
- Conduct a quick quiz in order to test the participants understanding and move on to the next section



## 1.5: Ohm's Law

Ask



- Ask the students about their understanding of the important terminologies
- Ask them to work in their respective teams and identify some common terminologies related to Ohm's law

Say



Ohm's law states that a voltage  $V$ , across a resistor  $R$ , is directly proportional to the current  $I$  flowing through the resistor. The following figure represents the mathematical expression of Ohm's law:

$$\text{Current (I)} = \frac{\text{Voltage (V)}}{\text{Resistance (R)}} \text{ in Amperes (A)}$$

Do



- Share with the help of relevant materials, important terminologies with the participants
- Play games to quiz the participants of their understanding
- Make sure that you give enough time to students for practicing before holding the quiz

Notes



- Facilitate the discussion and avoid arguments
- Summarise with the help of relevant materials
- Check participants understanding and move on to the next section

## 1. .6: Power

### Ask



- Ask the students about their understanding of the Electric Power
- Ask them to work in their respective teams and discuss power concept

### Say



Electrical power is measured in Watt (W). 1 W of power is equal to the work done by 1 V of voltage in one second, in moving 1 C of charge through a circuit. As an ampere is equal to 1 C per second, hence, the power will be denoted as volts times amperes. It is shown as:

$$P = V \times I$$

A resistor may be used in any combination of current and voltage until its 'dissipating power rating' is exceeded. Power rating of a resistor, known as wattage, indicates the amount of heat the resistor can dissipate safely before getting damaged. If more heat is produced by a resistor than that it can dissipate, it will be overheated and damaged. The following figure shows the calculation of power:

$$\text{Power, (P)} = V \times I = I^2 \times R = \frac{V^2}{R} \text{ Watts}$$

### Do



- Share with the help of the relevant material the details of Electric Power
- Explain Resistor
- Signal transmission

### Notes



- Facilitate the discussion and avoid arguments
- Summarise with the help of relevant material. Refer to the relevant sections on page of the participant's hand book
- Conduct a quick quiz in order to test the participants understanding and move on to the next section

### Activity

- Conduct a presentation activity.
- Ask the students to assemble in their teams, facilitator to provide each team with a chart paper
- Participants to discuss and make presentation about optical fibre technology, terminology, various transmission media etc.
- At the end of 15 minutes they have to present it to the class; presentation time 5 minutes

## 1.1.7: Inductance

### Ask



- Ask the students about their understanding of the Inductance
- Ask them to work in their respective teams and discuss self - Inductance

### Say



A magnetic field is built up around a length of wire when electric current flows through it. The relation between the direction of current flow and direction of the lines of force of the magnetic field can be understood by taking the example of a wooden screw being tightened into the conductor. The direction in which it would be tightened would represent the direction of current flow and the direction in which the head of the screw would be turned would represent the direction of the lines of force.

The magnetic flux of a single straight length of a wire can be increased manifold by forming a coil of N turns with it. Also, the value of the magnetic flux around the coil can be increased by increasing the magnitude of the current flowing through the coil's conductor.

### Do



- Share with the help of the relevant material the details of inductors
- Magnetic properties of the central core of a coil
- Explain different inductor symbols

### Notes



- Facilitate the discussion and avoid arguments
- Summarise with the help of relevant material. Refer to the relevant sections on page of the participant's hand book
- Conduct a quick quiz in order to test the participants understanding and move on to the next section

### Activity

- Conduct a presentation activity.
- Ask the students to assemble in their teams, facilitator to provide each team with a chart paper
- Participants to discuss and make presentation about optical fibre technology, terminology, various transmission media etc.
- At the end of 15 minutes they have to present it to the class; presentation time 5 minutes

## 1.1.8: Capacitance

### Ask



- Ask the students about their understanding of the Capacitance
- Ask them to work in their respective teams and discuss unit of capacitance and types of capacitors

### Say



A capacitor is a device that can store energy in the form of electrical charge. It thereby generates a potential difference across its multiple conductive plates. These plates can be of metal or foil and are parallel to each other. There is no connection between the plates. They are electrically separated either by air or some insulating material. Paper, ceramic, mica and plastic are examples of the insulating material used for this purpose. The plates are commonly known as capacitor's dielectric.

The unit of capacitance is Farad (F). The different types of capacitors are named according to the dielectric materials used in their construction. This is because the performance of a capacitor depends on the kind of material used for its dielectric.

The different kinds of capacitors include disc and tubular ceramics. These can be made from titanium oxide or aluminium oxide, silvered mica or metallised film. These films are made by using strips of oiled or waxed paper and aluminium foil or with plastic dielectrics like mylar, polyester, polyethylene, polycarbonate and polypropylene.

The types of capacitors also include large electrolytic capacitors in the form of polarised or non-polarised tantalum electrolytic capacitors and aluminium electrolytic capacitors. The following figure shows different capacitor symbols:

### Do



- Share with the help of the relevant material the details of Capacitor
- Explain kinds of capacitor
- Types of capacitor

### Notes



- Facilitate the discussion and avoid arguments
- Summarise with the help of relevant material. Refer to the relevant sections on page of the participant's hand book
- Conduct a quick quiz in order to test the participants understanding and move on to the next section

## 1.1.9: Series Connection

### Ask

- Ask the students about their understanding of the Series Connection
- Ask them to work in their respective teams and discuss Series Connection

### Say

When the resistors are connected together in a single line, a series connection is formed. A common current flow through all the resistors connected in series as there is only one path for the current to flow. In a series connection:

$$IR_1 = IR_2 = IR_3 = IR_4$$

The following figure shows a series connection and the formulae for calculation of different parameters:

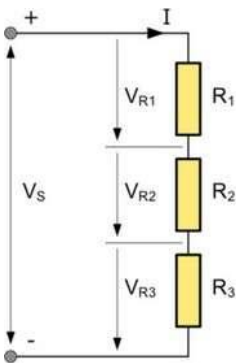

$$R_T = R_1 + R_2 + R_3 + \dots$$

$$V_S = V_{R1} + V_{R2} + V_{R3} + \dots$$

$$I = \frac{V_S}{R_T} = \frac{V_{R1}}{R_1} = \frac{V_{R2}}{R_2} = \frac{V_{R3}}{R_3}$$

### Do

- Share with the help of the relevant material the details of Series Connection
- Different parameters of Series Connection

### Notes

- Facilitate the discussion and avoid arguments
- Summarise with the help of relevant material. Refer to the relevant sections on page 9 of the participant's hand book
- Conduct a quick quiz in order to test the participants understanding and move on to the next section

## 1.1.10: Parallel Connection

### Ask

- Ask the students about their understanding of the Parallel connection
- Ask them to work in their respective teams and discuss Parallel connection

### Say

A parallel connection is formed when the terminals of the resistors are connected respectively to each terminal of other resistors. Unlike a series connection, in a parallel connection the current can flow through multiple paths.

The current flowing through the parallel circuit is not same at all points, since there is more than one path for the current to flow through. However, the voltage drop across all resistors connected in parallel is same. There is a common voltage across all elements in parallel connection in a circuit. The following figure shows a parallel connection and the formulae for calculation of different parameters:

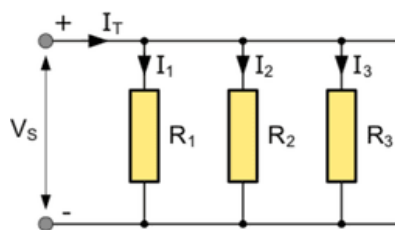

$$\frac{1}{R_T} = \frac{1}{R_1} + \frac{1}{R_2} + \frac{1}{R_3} + \dots$$

$$I_T = I_1 + I_2 + I_3 + \dots$$

$$V_S = I_{R1} = I_{R2} = I_{R3} = \dots$$

### Do

- Share with the help of the relevant material the details of Parallel Connection
- Different parameters of Parallel Connection

### Notes

- Facilitate the discussion and avoid arguments
- Summarise with the help of relevant material. Refer to the relevant sections on page of the participant's hand book
- Conduct a quick quiz in order to test the participants understanding and move on to the next section

## UNIT 1.2: Basic Functionality of Common Electronic Components

### Unit Objectives



**At the end of this unit, students will be able to:**

1. List the types of electronic components
2. Identify the applications of diodes and transistors
3. Demonstrate the functions of different logic gates
4. Assess the applications of transmitters and receivers
5. Distinguish between different types of switches
6. Identify different power supplies
7. Classify different types of amplifiers
8. List the applications of multiplexers and demultiplexers

### Facilitation Notes



- You could ask the students what they know about Electric Components
- Give students some time to think about how the telecom industry in India operates
- Give students some time to think about applications of transmitters and receivers
- Set the context and describe the industry trends in telecom and significance of Electronics

## .2.1: Types of Electronic Components

### Say



Basically, there are two types of electronic components; active components and passive components.

#### Active Components

Active components refer to those components which require external power supply to operate them such as diode, transistor, integrated circuits, mosfets and so on.

#### Passive Components

As their name suggests, passive components do not require any electrical power to operate, unlike the active devices that need to be powered to make them work.

Passive devices do not offer amplification, gain or directionality to a circuit. But they provide attenuation to the circuit as they have a gain less than unity. Hence, the passive devices cannot generate, amplify or oscillate an electrical signal.

Passive devices can be used individually. They are used to control complex circuits or signals by getting connected together in series or in parallel combination. They are also used for generating a phase shift to signal or providing some form of feedback. But, since these devices have no power gain, they cannot multiply a signal by more than one.

Passive devices consume power in a circuit. They act like attenuators, whereas the active devices provide power to a circuit.

Passive devices are bi-directional components. Thus, in a circuit, they can be connected either way if they don't have a polarity marking; for example, electrolytic capacitors. The flow of the current from the positive to negative terminal determines the polarity of the voltage across the passive devices.

Some basic passive elements are resistor, capacitor and inductor.

### Do



- Refer to the relevant slides in the presentation and share it with the participants
- Share with the participants about telecom Industry Growth – benefits accrued

### Notes



- Facilitate the discussion and avoid arguments
- Summarise with the help of relevant material. Refer to the relevant sections on page 11 of the participant's hand book
- Conduct a quick quiz in order to test the participants understanding and move on to the next section



## 1.2.2: Diode

### Say

A diode is an electrical semiconductor device. It works as a one-way switch to permit the current to flow through it in one direction only. A diode shows an exponential I-V relationship and hence, it does not have a linear relationship with the applied voltage. Therefore, its operation cannot be explained using equations such as Ohm's law. The following figure shows the I-V characteristics of a diode:

Diode I-V Characteristics

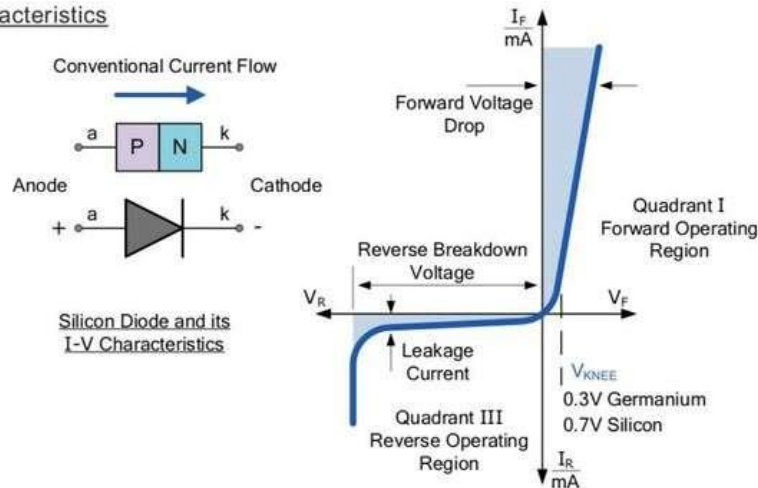

### Ask

- Ask the students about the applications of Diode
- Ask the students to explain the Zener Diode

### Notes

- Divide the students within groups and assign to explore about applications of Diode
- Give each group to prepare presentation for around 15 minutes
- Give 5 minutes to each group for presentation

### Do

- Ask the students to raise questions regarding any confusion
- Ensure active participation of each student

### Notes

- Ensure participation and also facilitate the activity within each team
- Facilitate the discussion and avoid arguments
- Summarise with the help of relevant presentation slide. Refer to page 4 of the participant's manual

## 1.2.3: Transistor

### Say

A transistor is an electronic semiconductor device. It is made by including a semiconductor layer in a PN-junction diode. Whenever there a minute change in the current flowing in one lead, the transistor functions as a conductor or an insulator. It produces a considerable change in the current, voltage and power with its other two leads. The two fundamental functions of a transistor within an electrical circuit are as follows:

- Amplification (in analog circuits)
- Switching (in digital circuits)

The following shows the interpretation of the circuit diagrams of two type transistors:

The arrows in the circuit in the above diagram represent the direction of the conventional current flow between the base and the emitter terminal.

For both transistor types, the direction of the arrow points from positive P-type region to negative N-type region, which is same as for a standard diode symbol.

### Do

- Refer to the relevant sections on page 16 - 19 of the participant's handbook
  - Ask the students to raise questions regarding any confusion
  - Ensure active participation of each student

### Notes for Facilitation

- Ensure participation and also facilitate the activity amongst the students
- Facilitate the discussion and avoid arguments
- Summarise with the help of relevant presentation slides. Refer to page 16 - 19 of the participant's hand book
- Conduct a quick quiz in order to test the participants understanding
- Move on to the next section

## 1.2.4: Logic Gates

Ask



- Ask the students about their understanding of the Logic Gates
- Ask the students to list the basic logic gates, their symbols and truth tables

Say



Logic gates are electronic circuits that are used to process signals which represent true or false. Normally, the positive supply voltage (typically +5 V) is represented true and 0 V is represented as false. The following figure lists the terms related to logic states:

Logic States	
True	False
1	0
High	Low
On	Off
+5V	0V

Do



- Share with the participants the various basic logic gates, their symbols and truth tables and universal logic gates, their symbols and truth tables and combinational logic gates, their symbols and truth tables
- Share with the participants the significance of logic gates

### Notes for Facilitation



- Facilitate the discussion and avoid arguments
- Summarise with the help of relevant material. Refer to the relevant sections on page 19 - 21 of the participant's handbook
- Conduct a quick quiz in order to test the participants understanding and move on to the next section

## 1.2.5: Transmitter

Ask



- Ask the students about their understanding of the important terminologies
- Ask them to work in their respective teams and identify some common terminologies related to Transmitter

Say



A Transmitter is defined as a combination of one or multiple electronic circuits or devices which converts the source information, also called as baseband signal, to a form suitable for transmission. Transmitters are used in the system where the sender encodes the information. AM radio transmitters and mobile phones are some of the examples. The following figure lists some characteristics of transmitters:

It must generate a signal of desired frequency.

It must provide some form of modulation that allows the information signal to modify a signal of higher frequency, also known as the carrier signal. Amplitude Modulation (AM) and Frequency Modulation are commonly used in broadcasting.

It must provide power amplification to ensure that the signal level is high. This should be in such a way that it will carry over the desired distance for which the signal is to be sent.

Do



- Share with the help of relevant materials, important terminologies with the participants
- Play games to quiz the participants of their understanding
- Make sure that you give enough time to students for practicing before holding the quiz

Notes for Facilitation



- Facilitate the discussion and avoid arguments
- Summarise with the help of relevant materials
- Check participants understanding and move on to the next section

## 1.2.6: Receiver

### Ask

- Ask the students about their understanding of the Receiver
- Ask them to work in their respective teams and discuss about Communication Systems

### Say

A receiver is a collection of various electronic circuits and devices which accepts the signals transmitted from the transmission medium and then converts them back to their original form understandable by humans. Television is a good example of a receiver. The following figure lists the primary requirements for a communication receiver: Selectivity and Sensitivity

### Do

- Share with the help of the relevant material the details of Receiver and Communication System

The following figure shows an overall communication system:

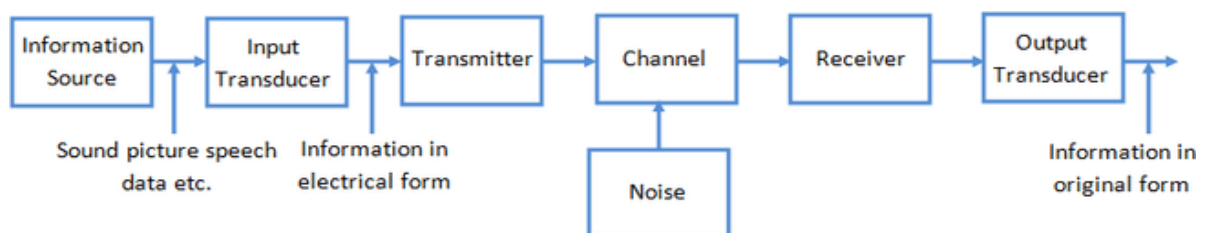

### Notes for Facilitation

- Facilitate the discussion and avoid arguments
- Summarise with the help of relevant material. Refer to the relevant sections on page 22 of the participant's hand book
- Conduct a quick quiz in order to test the participants understanding and move on to the next section

### Activity

- Conduct a presentation activity.
- Ask the students to assemble in their teams, facilitator to provide each team with a chart paper
- Participants to discuss and make presentation
- At the end of 15 minutes they have to present it to the class; presentation time 5 minutes

## 1.2. : Switches

### Ask

- Ask the students about their understanding of the Switches
- Ask them to work in their respective teams and discuss basic types of switches

### Say

A switch can automatically or manually connect or break an electrical circuit. It mainly works with an ON (open) and OFF (closed) mechanism. The following figure lists the basic types of switches:

Single Pole Single  
Throw (SPST)

Single Pole Double  
Throw (SPDT)

Double Pole Single  
Throw (DPST)

Double Pole Double  
Throw (DPDT)

### Do

- Share with the help of the relevant material the details of switches
- Talk about different switches and its circuits

### Notes for Facilitation

- Facilitate the discussion and avoid arguments
- Summarise with the help of relevant material. Refer to the relevant sections on page 22 - 25 of the participant's hand book
- Conduct a quick quiz in order to test the participants understanding and move on to the next section

### Activity

- Conduct a presentation activity.
- Ask the students to assemble in their teams, facilitator to provide each team with a chart paper
- Participants to discuss and make presentation
- At the end of 15 minutes they have to present it to the class; presentation time 5 minutes

## 1.2.8: Power Supply

### Ask



- Ask the students about their understanding of the Power Supply
- Ask them to work in their respective teams and discuss unit of capacitance and types of capacitors

### Say



A capacitor is a device that can store energy in the form of electrical charge. It thereby generates a potential difference across its multiple conductive plates. These plates can be of metal or foil and are parallel to each other. There is no connection between the plates. They are electrically separated either by air or some insulating material. Paper, ceramic, mica and plastic are examples of the insulating material used for this purpose. The plates are commonly known as capacitor's dielectric.

The unit of capacitance is Farad (F). The different types of capacitors are named according to the dielectric materials used in their construction. This is because the performance of a capacitor depends on the kind of material used for its dielectric.

The different kinds of capacitors include disc and tubular ceramics. These can be made from titanium oxide or aluminium oxide, silvered mica or metallised film. These films are made by using strips of oiled or waxed paper and aluminium foil or with plastic dielectrics like mylar, polyester, polyethylene, polycarbonate and polypropylene.

The types of capacitors also include large electrolytic capacitors in the form of polarised or non-polarised tantalum electrolytic capacitors and aluminium electrolytic capacitors. The following figure shows different capacitor symbols:

### Do



- Share with the help of the relevant material the details of capacitor
- Explain kinds of capacitor
- types of capacitor

### Notes for Facilitation



- Facilitate the discussion and avoid arguments
- Summarise with the help of relevant material. Refer to the relevant sections in participant's hand book
- Conduct a quick quiz in order to test the participants understanding and move on to the next section

## 1. . . : Series onnection

Ask



- Ask the students about their understanding of the Series onnection
- Ask them to work in their respective teams and discuss Series onnection

Say



When the resistors are connected together in a single line, a series connection is formed. A common current flow through all the resistors connected in series as there is only one path for the current to flow. In a series connection:

$$IR_1 = IR_2 = IR_3 = IR_4$$

The following figure shows a series connection and the formulae for calculation of different parameters:

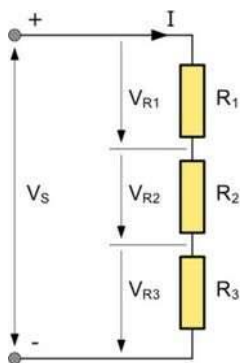

$$R_T = R_1 + R_2 + R_3 + \dots$$

$$V_S = V_{R1} + V_{R2} + V_{R3} + \dots$$

$$I = \frac{V_S}{R_T} = \frac{V_{R1}}{R_1} = \frac{V_{R2}}{R_2} = \frac{V_{R3}}{R_3}$$

Do



- Share with the help of the relevant material the details of Series onnection
- Different parameters of Series onnection

## Notes for Facilitation



- Facilitate the discussion and avoid arguments
- Summarise with the help of relevant material. Refer to the relevant sections on page of the participant's hand book
- Conduct a quick quiz in order to test the participants understanding and move on to the next section



## 1. . . : Parallel onnection

Ask



- Ask the students about their understanding of the Parallel onnection
- Ask them to work in their respective teams and discuss Parallel onnection

Say



A parallel connection is formed when the terminals of the resistors are connected respectively to each terminal of other resistors. Unlike a series connection, in a parallel connection the current can flow through multiple paths.

The current flowing through the parallel circuit is not same at all points, since there is more than one path for the current to flow through. However, the voltage drop across all resistors connected in parallel is same. There is a common voltage across all elements in parallel connection in a circuit. The following figure shows a parallel connection and the formulae for calculation of different parameters:

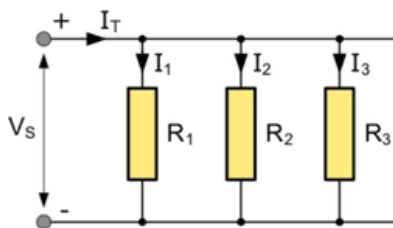

$$\frac{1}{R_T} = \frac{1}{R_1} + \frac{1}{R_2} + \frac{1}{R_3} + \dots$$

$$I_T = I_1 + I_2 + I_3 + \dots$$

$$V_S = I_{R1} = I_{R2} = I_{R3} = \dots$$

Do



- Share with the help of the relevant material the details of Parallel onnection
- Different parameters of Parallel onnection

Notes for Facilitation



- Facilitate the discussion and avoid arguments
- Summarise with the help of relevant material. Refer to the relevant sections on page of the participant's hand book
- Conduct a quick quiz in order to test the participants understanding and move on to the next section

## Answers to exercises for PHB

### Unit 1.1 Exercise

#### Multiple Choice Questions:

a

a

a

#### Fill in the blanks:

fiber optic converters

Rugged or remote locations

#### True/False:

true

false

#### Descriptive:

Refer to the brief overview of telecom & fiber optics roadband Industry

Refer to the brief overview of telecom & fiber optics. Slide & Scope of telecom industry and its Subsectors

Refer to the brief overview of telecom & fiber optics. Slide & Scope of telecom industry and its Subsectors

Refer to the brief overview of telecom & fiber optics. Public Switched telephone network (PSTN)

Refer to the brief overview of telecom & fiber optics. Important terminologies

Refer to the brief overview of telecom & fiber optics. Important terminologies

Refer to the brief overview of telecom & fiber optics. Important terminologies

Refer to the brief overview of telecom & fiber optics. Important terminologies

Refer to the brief overview of telecom & fiber optics. Important terminologies

Refer to the brief overview of telecom & fiber optics. Important terminologies

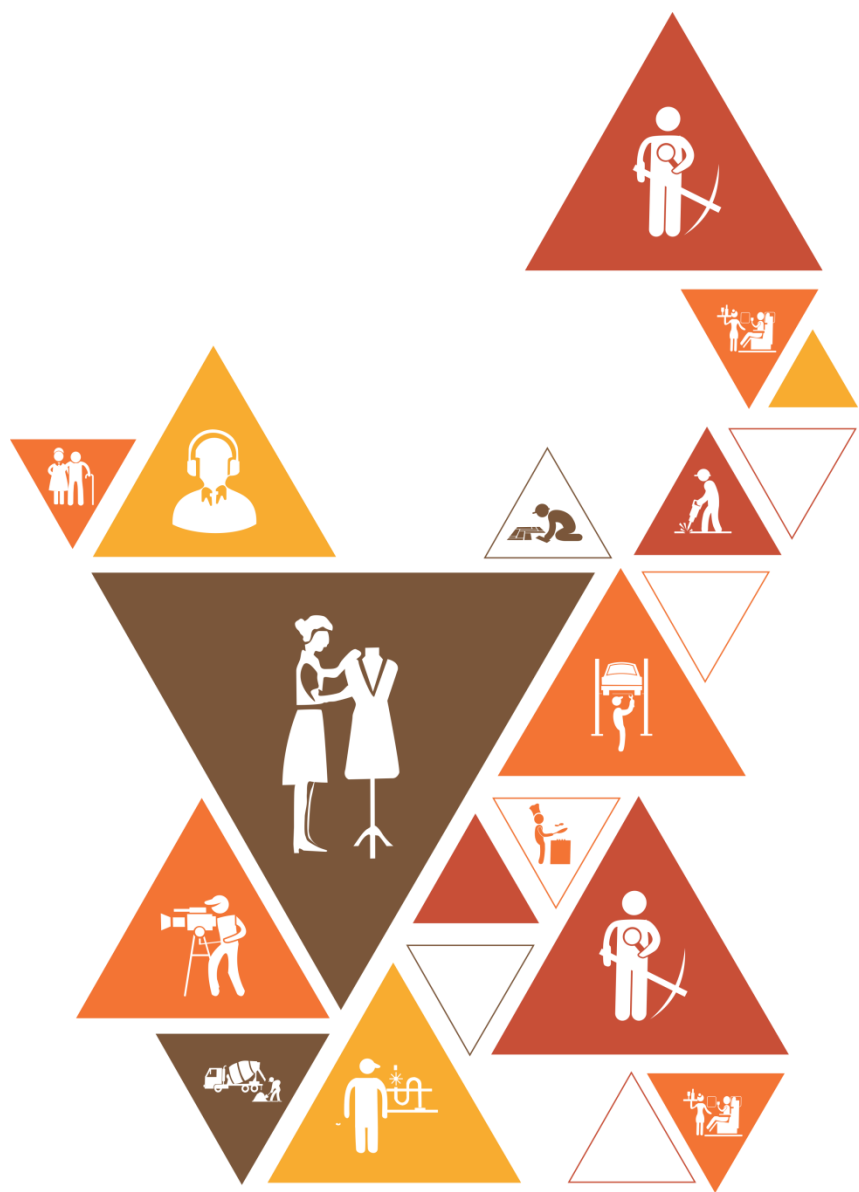



**Skill India**  
कौशल भारत - कुशल भारत



सत्यमेव जयते  
GOVERNMENT OF INDIA  
MINISTRY OF SKILL DEVELOPMENT  
& ENTREPRENEURSHIP



N · S · D · C  
National  
Skill Development  
Corporation

Transforming the skill landscape



## 2. Carry out inspection of Route Plan

- nit Site visit and route inspection
- nit choosing the right type of optic fiber cable
- nit tools and equipment
- nit Installation of fiber optic cable

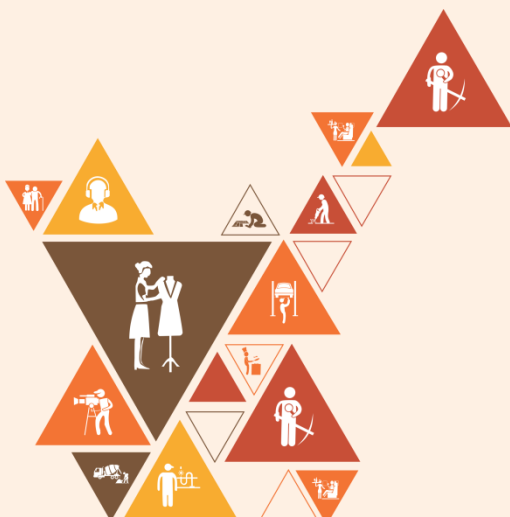

TEL/N4137

## Key Learning Outcomes

**At the end of this module, students will be able to:**

1. Perform an effective site visit
2. Describe, demonstrate and monitor an effective route inspection
3. Describe the advantages of an effective route inspection
4. Identify and make use of common fiber optic tools and tool kit
5. Explain and outline the benefits of fiber optic cable specification and the factors affecting it
6. Describe, demonstrate and monitor the correct procedure of handling the fiber optic cable
7. Describe, demonstrate and monitor the optical fiber laying pre-requisites
8. Describe, demonstrate and monitor the correct procedure of - trenching, aerial cabling, ducting, figure-eight, cable pulling, blowing and termination of an optical fiber
9. Explain and illustrate the reports required to document steps undertaken during troubleshooting

## UNIT 2.1: Site Visit & Route Inspection

### Unit Objectives



**At the end of this unit, students will be able to:**

1. Perform an effective site visit
2. Explain and outline route inspection and its benefits
3. Perform an effective route inspection by demonstrating proper steps

### Notes for Facilitation



- You could ask the students what they know about site visit
- Also ask the students what they know about route inspection and its benefits
- Give students some time to think and discuss amongst themselves
- Set the context before explaining to them in detail about site visit and route inspection

## 2.1.1: Site Visit

### Ask

- Ask the students about their understanding of site visit
- Ask them to work in their respective teams and identify the various aspect of site visit and their benefits

### Say

- Having understood the telecom optical fibre industry, it's time to discuss the procedure for installation and commissioning of optical fibre cable
- However, the first thing that we will start with is a – site visit

### Do

- Share with the help of the relevant material the details about the site visit
- It is necessary that students are taken to a location of actual site visit, so as to help them understand the same

### Notes for Facilitation

- Facilitate the discussion and avoid arguments
- Discuss the positioning of various parts and sections in detail
- Summarise with the help of relevant materials. Refer to the relevant sections on page 24 of the participant's hand book
- Conduct a quick quiz in order to test the participants understanding and move on to the next section

### Demonstrate

- Plan a visit for the students, to an actual site where an optical fibre cable laying is happening
- Demonstrate the various components of the site visit in detail
- Demonstrate the benefits a site visit

## 2.1.2: Route Inspection and its Benefits

### Ask

- Ask the students about what do you understand by route inspection?
- Ask the students to list the various benefits of route inspection?

### Say

- In this session we would learn about route inspection and its benefits
- Rout inspection is a planned activity and is extremely beneficial

### Do

- Share with the help of the facilitator's material – route inspection
- Share with the help of the facilitator's material – route inspection benefits

### Notes for Facilitation

- Facilitate the discussion and avoid arguments
- Discuss route inspection detail
- Discuss the various benefits of route inspection in detail
- Summarise with the help of relevant material. Refer to the relevant sections on page 25 of the participant's hand book
- Conduct a quick quiz in order to test the participants understanding and move on to the next section

### Demonstrate

- Plan a visit for the students, to an actual site where an optical fibre cable laying is happening
- Demonstrate the various components of the site visit in detail
- Demonstrate the benefits a site visit



## 2.1.3: Steps to Route Inspection

### Ask

- Ask the students to list the various steps involved in route inspection
- Ask the students to discuss amongst themselves

### Say

- In this session we would learn about the steps involved in route inspection
- Observe what is happening on the site (during the site visit)

### Steps: Soldering

**Step 1**– Obtain an OFC route plan.

**Step 2**– Verify the plan through a 'Route Walk'.

**Step 3**– Take corrective actions.

### Notes for Facilitation

- Facilitate the discussion and avoid arguments
- Discuss the various route inspection steps in detail
- Summarise with the help of material. Refer to page 26 of the participant's hand book
- Conduct a quick quiz to test the participants understanding

### Demonstrate

- Plan an actual route inspection with the help of a service provider / contractor
- Demonstrate to the participants the details of route inspection
- Demonstration to be conducted by experienced staff members of the team present

### 2.1.3.1: Obtain 'OFC' Route Plan

#### Ask

- Ask the students the meaning of the word 'plan' in general
- Ask the students about what do you understand by an 'OFC' route plan

#### Say

- In this session we would learn about OFC route plan
- In this session we would learn about various aspects of an OFC route plan

#### Do

- Share with the participants details about the various aspects of an 'OFC' route plan
- Physical locations (premises or outside plant) along the route.
- Other utilities, cables etc. so that damages are avoided.
- Departments involved – electricity, water, municipality, etc.
- Permission(s) required carrying out the entire activity.
- Physical obstacles & health hazards along the route.

#### Notes for Facilitation

- Facilitate the discussion and avoid arguments
- Discuss the various aspects of an 'OFC' route plan and its need
- Share multiple copies of the 'OFC' route plan
- Summarise with the help of slides. Refer to page 26 of the participant's hand book
- Conduct a quick quiz to test the participants understanding and move to the next section

#### Demonstrate

- Plan an actual route inspection with the help of a service provider / contractor
- Demonstrate to the participants the details of an 'OFC' route plan
- Demonstration to be conducted by experienced staff members of the team present

## 2.1.3.2: Verify Plan – ‘Route Walk’

### Ask

- Ask the students about what do you understand by – verify plan
- Ask the students what is the meaning of the term ‘route walk’

### Say

- In this session we would learn about the steps, next to obtaining and studying an OFC route plan
- In this session we would also learn about ‘route walk’

### Do

- Share with the participants details about the ‘route walk’
- Verify the ‘plan’ for accessibility and availability as per design.
- Verify construction methods, special tools, splice locations, etc.
- Verify ground characteristics including subsurface investigation; it helps allay fears related to trenching / ploughing.
- Draw and mark bends, conduit size, splice locations, manholes, etc., so as to begin any preparatory or co-ordination work (Ref. next page).
- Mark the proximity to AC power areas to avoid possibility of damages / accidents

### Notes for Facilitation

- Facilitate the discussion and avoid arguments
- Discuss the various aspects of the route walk
- Summarise with the help of slides. Refer to page 27 of the participant’s hand book
- Conduct a quick quiz to test the participants understanding and move to the next section

### Demonstrate

- Plan an actual ‘route walk’ with the help of a service provider / contractor
- Demonstrate to the participants an actual ‘route walk’
- Demonstration to be conducted by experienced staff members of the team present

### 2.1.3.3: Take Corrective Actions

#### Ask



- Ask the students about what do you understand by – corrective actions
- Ask the students what is the meaning of the term ‘corrective actions’

#### Say



- In this session we would learn about the steps, next to obtaining and studying an OFC route plan
- In this session we would also learn about ‘route walk’

#### Do



- Share with the participants details about the ‘corrective actions’
- Take permissions from other departments, etc. if required.
- Revise routes – bends, splicer locations, etc. if required. Arrange for special tools if required.
- Remove or circumvent any obstruction / conflict along the route for better productivity
- If the route contains sections where the optical cable is subject to high temperatures, provide necessary protection.
- Take measures to prevent optical cables from direct stress.
- Determine locations where reels are to be positioned during the installation.

#### Notes for Facilitation



- Facilitate the discussion and avoid arguments
- Discuss the various aspects of corrective action
- Summarise with the help of slides. Refer to page 28 of the participant’s hand book
- Conduct a quick quiz to test the participants understanding and move to the next section

#### Demonstrate



- Take corrective actions with the help of a service provider / contractor
- Demonstrate to the participants an actual ‘corrective actions’
- Demonstration to be conducted by experienced staff members of the team present

## UNIT 2.2: Choosing the right type of optical fibre cable

### Unit Objectives



**At the end of this unit, students will be able to:**

- Choose the type of optical fiber based on the location
- Define the characteristics of Single and multimode optical fiber
- Explain how to select the type of optical fiber

### Notes for Facilitation



- You could ask the students what they know about the type of optical fibre and on what basis they should choose
- Give students some time to think about it
- Set the context and at the same time ask the students to list their thoughts

## 2.2.1: Choosing between Single mode vs Multimode optical fibre

### Ask



- Ask the students about their understanding of mode
- Ask them to work in their respective teams and identify the type of modes of optical fibre

### Say



- The manner an optical wave is transmitted is often referred to as the mode. As they reach the optical fiber, uniformly frequencies optical waves are dispersed along several transmission routes. Mode is the name given to the specific path that each individual optical wave takes.

### Do



- Share with the help of relevant materials the basic check to be conducted on the mode
- The Helmholtz equation for waves is used to compute the number of modes in a fiber optic cable. Applying boundary conditions to Maxwell's equation results in the actual Helmholtz equation. The profitable solutions of Maxwell's equation are the fiber optic modes as a result.
- Make a note of the quantity of glass fiber strands wrapped inside the cladding has absolutely no bearing on the modal dispersion.

## Notes for Facilitation



- Facilitate the discussion and avoid arguments
- Discuss Helmholtz equation
- Summarise with the help of relevant facilitator material. Refer to page 29-30 of the handbook
- Conduct a quiz in order to test the participants understanding and move to the next section

## Demonstrate



- Demonstrate a proper tool kit to the students
- Demonstrate the basic checks to be conducted on the tool-kit
- Also ask the students to demonstrate the appropriate use of a tool-kit

## 2.2: Overview of Single mode optical fiber

### Ask

- Ask the students about their understanding of the Single mode optical fiber
- Ask them to work in their respective teams and identify the characteristics

### Say

- Let us now single mode optical fiber is a specific kind of optical fiber made for the transmission of single mode light. This indicates that this particular type of optical fiber allows the transmission of various light waves with various frequencies along a single channel. The preferred abbreviation for these single mode optical fibers in the sector is S

### Do

- Share with the help of relevant materials – various tools
- Also share with the students characteristics of Single mode optical fiber

### Notes for Facilitation

- Facilitate the discussion and avoid arguments
- Discuss the various tools and their use in detail
- Summarise with the help of relevant facilitation materials. Refer to page - of the hand book
- Conduct a quiz in order to test the participants understanding and move to the next section

### Demonstrate

- Demonstrate the various tools to the students
- Demonstrate its use and explain their purpose
- Also ask the students to demonstrate the various tools along with their respective use

## 2. . . : overview of multimode optical fiber

### Ask



- Ask the students about their understanding of multimode optical fiber
- Ask them to work in their respective teams and identify the characteristics

### Say



A type of optical fiber created for the propagation of several light signals is the multimode optical fiber. MM is the abbreviation used in industry for multimode optical fiber. According to the different optical signal wavelengths, modal dispersion occurs in MM. MM has increased modal dispersion as a result of MM. Depending on the refractive index of the glass core material, the optic wave propagation route in the MM is either OM3 or OM4 in shape.

### Do



- Share with the help of relevant materials various tools
- Also share with the students characteristics of Single mode optical fiber

### Notes for Facilitation



- Facilitate the discussion and avoid arguments
- Discuss the fibre optic tool kit and the basic checks to be conducted in detail
- Summarise with the help of relevant facilitator material. Refer to page 10 - 15 of the hand book
- Conduct a quiz in order to test the participants understanding and move to the next section

### Demonstrate



- Demonstrate a proper tool kit to the students
- Demonstrate the basic checks to be conducted on the tool-kit
- Also ask the students to demonstrate the appropriate use of a tool-kit



## UNIT 2. : Fibre Optics Tools & Tool Kit

### Unit Objectives



**At the end of this unit, students will be able to:**

1. Describe the importance of maintaining a proper and complete tool kit
2. Perform a basic check of the tool-kit
3. List the tools with their respective quantity and usage

### Notes for Facilitation



- You could ask the students what they know about the basic tools to repair a mobile phone
- Give students some time to think about the various tools and their function
- Set the context and at the same time ask the students to prepare a list of tools

## 2. .2: Fibre Optic Tools

### Ask



- Ask the students about their understanding of the various tools required for optical fibre installation
- Ask them to work in their respective teams and identify the various tools and their purpose

### Say



- Let us now list the various tools along with their respective purpose

### Do



- Share with the help of relevant materials – various tools
- Also share with the students the purpose of each of these tools

### Notes for Facilitation



- Facilitate the discussion and avoid arguments
- Discuss the various tools and their use in detail
- Summarise with the help of relevant facilitation materials. Refer to page 31-38 of the hand book
- Conduct a quiz in order to test the participants understanding and move to the next section

### Demonstrate



- Demonstrate the various tools to the students
- Demonstrate its use and explain their purpose
- Also ask the students to demonstrate the various tools along with their respective use

## UNIT 2. : Installation of Fibre Optic Cable

### Unit Objectives



**At the end of this unit, students will be able to:**

1. Describe fiber optic cable specification – tensile strength, bend radius, crush and impact, cable attenuation, fiber optic connectivity
2. Explain and outline factors effecting fiber optic cable – natural and man made
3. Demonstrate the correct procedure of – unloading, unwrapping, storage, drum preparation and opening of optical fiber cable
4. Demonstrate and execute optical fiber laying pre-requisites
5. Describe, demonstrate and monitor installation of optical fiber – trenching, aerial cabling, ducting, figure-eight, cable pulling, blowing and termination
6. Perform effective tests
7. Demonstrate effective reporting and documentation skills

### Notes for Facilitation



- You could ask the students what they know about fibre optic cable specification
- Give students some time to think about the various factors effecting fibre optic cable installation
- You could ask the students what is the right way of handling optical fibre cable
- Give students some time to think about fibre optic cable laying pre-requisites
- Give students some time to think about the various types of optical fibre cable installation technique
- You could ask the students about the various tests to check fibre optic cable installation
- Set the context and at the same time ask the students to prepare for an installation of optical fibre cable

## 2. .1.1: Fibre Optic Cable Specification – Tensile Strength



- Welcome and greet the participants. Revise the learning of the previous sessions and ask them if they have any doubts.



- Having understood details about the fibre optic tools and tool kit
- Also let us understand and outline fibre optic cable specification – tensile strength



- Share with the participants details about ‘tensile strength’
- Share with the participants details about ‘short term load’ and ‘operating load’
- Share the related precautions with the participants



- Demonstrate the ‘cable data sheet’ to the students
- Share with the students the basic precautions while installing the cable



- Facilitate the discussion and avoid arguments
- Discuss the various aspects of tensile strength
- Summarise with the help of slides. Refer to page 39 of the participant’s hand book
- Conduct a quick quiz to test the participants understanding and move to the next section

## 2. .1.2: Fibre Optic Cable Specification – Bend Radius



- Welcome and greet the participants. Revise the learning of the previous sessions and ask them if they have any doubts.



- Having understood details the fibre optic cable specification – tensile strength
- Also let us understand and outline fibre optic cable specification – bend radius



- Share with the participants details about ‘bend radius’
- Share with the participants details about ‘installing’ and ‘long term’ bend radius
- Share the related precautions with the participants



- Demonstrate the ‘cable data sheet’ to the students, so as to understand the value of the recommended bend radius
- Share with the students the basic precautions while installing the cable



- Facilitate the discussion and avoid arguments
- Discuss the various aspects of bend radius
- Summarise with the help of slides. Refer to page 40 of the participant’s hand book
- Conduct a quick quiz to test the participants understanding and move to the next section

## 2. .1.3: Fibre Optic Cable Specification – Crush and Impact

### Do

- Welcome and greet the participants. Revise the learning of the previous sessions and ask them if they have any doubts.

### Say

- Having understood details the fibre optic cable specification – bend radius
- Also let us understand and outline fibre optic cable specification – crush and impact

### Do

- Share with the participants details about ‘crush and impact’
- Share the related precautions with the participants

### Demonstrate

- Demonstrate the crush and impact situations to the students
- Share with the students the basic precautions while installing the cable

### Notes for Facilitation

- Facilitate the discussion and avoid arguments
- Discuss the various aspects of crush and impact
- Summarise with the help of slides. Refer to page 41 of the participant’s hand book
- Conduct a quick quiz to test the participants understanding and move to the next section

## 2. .1.4: Fibre Optic Cable Specification – Attenuation

### Do

- Welcome and greet the participants. Revise the learning of the previous sessions and ask them if they have any doubts.

### Say

- Having understood details the fibre optic cable specification – crush and impact
- Also let us understand and outline fibre optic cable specification – attenuation

### Do

- Share with the participants details about ‘attenuation’
- Share the related precautions with the participants

### Demonstrate

- Demonstrate the ‘attenuation’ related situations to the students
- Share with the students the basic precautions while installing the cable

### Notes for Facilitation

- Facilitate the discussion and avoid arguments
- Discuss the various aspects of ‘attenuation’
- Summarise with the help of slides. Refer to page 42 of the participant’s hand book
- Conduct a quick quiz to test the participants understanding and move to the next section

## 2. .1.4: Fibre Optic Cable Specification – Continuity

### Do

- Welcome and greet the participants. Revise the learning of the previous sessions and ask them if they have any doubts.

### Say

- Having understood details the fibre optic cable specification – attenuation
- Also let us understand and outline fibre optic cable specification – continuity

### Do

- Share with the participants details about ‘continuity’
- Share the related precautions with the participants

### Demonstrate

- Demonstrate the ‘continuity’ related situations to the students
- Share with the students the basic continuity checks before installing the cable

### Notes for Facilitation

- Facilitate the discussion and avoid arguments
- Discuss the various aspects of ‘continuity’
- Summarise with the help of slides. Refer to page 42 of the participant’s hand book
- Conduct a quick quiz to test the participants understanding and move to the next section



## 2. .2: Factors Affecting Optical Fibre Cable (OFC)



- Welcome and greet the participants. Revise the learning of the previous sessions and ask them if they have any doubts.



- Having understood details the fibre optic cable specifications
- Also let us understand and outline the factors affecting fibre optic cable



- Share with the participants the various factors affecting optical fibre cable
- Share the related precautions with the participants

### Notes for Facilitation

- Facilitate the discussion and avoid arguments
- Discuss the various factors that affect optical fibre cable both man-made and natural
- Assign the various teams presentation topics, and ask them to present the same
- Summarise with the help of page 43-44 of the participant's hand book
- Conduct a quick quiz to test the participants understanding and move to the next section

### Demonstrate

- Demonstrate the natural and man-made factors affecting fibre optic cable
- Share with the students the impact of these factors on the fibre optic cable

## 2. .2.1: Factors Affecting OFC – Choosing Cable

### Do

- Welcome and greet the participants. Revise the learning of the previous sessions and ask them if they have any doubts.

### Say

- Having understood details of the factors affecting fibre optic cable
- Also let us understand – how to choose an optical fibre cable?

### Do

- Share with the participants the various factors that help you to choose an appropriate optical fibre cable
- Share the related precautions with the participants

### Notes for Facilitation

- Facilitate the discussion and avoid arguments
- Discuss the various factors that help you chose an optical fibre cable
- Assign the various teams presentation topics, and ask them to present the same
- Summarise with the help of page 45 of the participant's hand book
- Conduct a quick quiz to test the participants understanding and move to the next section

### Demonstrate

- Demonstrate the natural and man-made factors affecting fibre optic cable
- Share with the students the impact of these factors on the fibre optic cable

## 2. .3: Handling Optical Fibre Cable



- Welcome and greet the participants. Revise the learning of the previous sessions and ask them if they have any doubts.



- Having understood details about how to choose an optical fibre cable?
- Also let us understand – how to handle an optical fibre cable?



- Share with the participants the various ways to handle optical fibre cable
- Share the related precautions with the participants

### Notes for Facilitation

- Facilitate the discussion and avoid arguments
- Discuss the various ways to handle an optical fibre cable – unloading, wrapping and storage
- Discuss the various OFC pre-installation checks – drum inspection, cable inspection
- Discuss OFC– drum opening and preparation
- Assign the various teams presentation topics, and ask them to present the same
- Summarise with the help of page 46-49 of the participant’s hand book
- Conduct a quick quiz to test the participants understanding and move to the next section

### Demonstrate

- Organize the trip of these participants to an OFC installation site
- Demonstrate the various ways to handle an OFC – unloading, wrapping and storage
- Demonstrate the various OFC pre-installation checks – drum inspection, cable inspection
- Demonstrate OFC– drum opening and preparation

## 2. .4: Installation of Optical Fibre Cable

### Do

- Welcome and greet the participants. Revise the learning of the previous sessions and ask them if they have any doubts.

### Say

- Having understood details about how to choose an optical fibre cable?
- Also let us understand installation of an optical fibre cable

### Do

- Share with the participants installation procedure of an optical fibre cable
- Share the related precautions with the participants

### Notes for Facilitation

- Facilitate the discussion and avoid arguments
- Discuss the procedure of installing an OFC – putting in cable, terminating and testing it
- Discuss the various OFC installation pre-requisites
- Summarise with the help of page 50 of the participant's hand book
- Conduct a quick quiz to test the participants understanding and move to the next section

### Demonstrate

- Organize the trip of these participants to an OFC installation site
- Demonstrate the installation procedure of an OFC – putting in cable, terminating and testing it
- Demonstrate the various OFC installation pre-requisites

## 2. .4: Steps OFC Installation



- Welcome and greet the participants. Revise the learning of the previous session and ask them if they have any doubts.



- Having broadly understood installation of an optical fibre cable
- Also let us identify, understand and demonstrate steps of OFC installation



- Demonstrate to the students the steps of installation of an OFC
- Share with the students the basics in order to conduct such an installation

### Steps: OFC Installation

**Step 1**– Installation through (a) trenching (b) Aerial.

**Step 2**– Ducting process.

**Step 3**– Conduct figure 8'ing'.

**Step 4**– Cable pulling and blowing.

**Step 3**– Cable termination.



- Summarize with the help of relevant facilitator's material. Refer to page 51 of the hand book

## 2. .4.1: Step (a) Trenching

### Do

- Welcome and greet the participants. Revise the learning of the previous sessions and ask them if they have any doubts.

### Say

- Having understood in detail about the steps for installation of optical fibre cable
- Let us now understand – trenching

### Do

- Share with the participants the various factors that one has to consider for trenching
- Share the related precautions with the participants

### Notes for Facilitation

- Facilitate the discussion and avoid arguments
- Discuss the various factors that help you consider during trenching
- Discuss the three main aspects of trenching – digging a hole, placing a cable and refilling it
- Summarise with the help of page 51-53 of the participant's hand book
- Conduct a quick quiz to test the participants understanding and move to the next section

### Demonstrate

- Organize the trip of these participants to an OFC installation site
- Discuss the three main aspects of trenching – digging a hole, placing a cable and refilling it
- Demonstrate the various OFC trenching precautions

## 2. .4.1: Step (b) Aerial Cabling



- Welcome and greet the participants. Revise the learning of the previous sessions and ask them if they have any doubts.



- Having understood in detail about trenching - for installation of optical fibre cable
- Let us now understand – aerial cabling



- Share with the participants the various factors that one has to consider for aerial cabling
- Share the related precautions with the participants

### Notes for Facilitation

- Facilitate the discussion and avoid arguments
- Discuss the various factors that help you consider during aerial cabling
- Discuss the main aspects of aerial cabling – messenger wires, lashing etc.
- Discuss with the participants the main features of aerial cabling
- Summarise with the help of page 53-54 of the participant's hand book
- Conduct a quick quiz to test the participants understanding and move to the next section

### Demonstrate

- Organize the trip of these participants to an OFC installation site
- Discuss the main aspects of aerial cabling – messenger wires, lashing etc
- Demonstrate the various precautions related to aerial cabling

## 2. .4.2: Step – Ducting Process

### Do

- Welcome and greet the participants. Revise the learning of the previous sessions and ask them if they have any doubts.

### Say

- Having understood in detail about aerial cabling - for installation of optical fibre cable
- Let us now understand – ducting process

### Do

- Share with the participants the various factors that one has to consider for ducting
- Share with the participants the key features of the ducting process
- Share the related precautions with the participants

### Notes for Facilitation

- Facilitate the discussion and avoid arguments
- Discuss the various factors that help you consider during ducting
- Discuss the main aspects of ducting – pull roper or tapes, unwinding and feeding the duct etc.
- Discuss with the participants the main features of the duct
- Discuss with the participants the advantages of ducting
- Summarise with the help of page 55-56 of the participant’s hand book
- Conduct a quick quiz to test the participants understanding and move to the next section

### Demonstrate

- Organize the trip of these participants to an OFC installation site
- Discuss the main aspects of cable ducting – pull roper or tapes, unwinding & feeding of duct etc.
- Demonstrate the various precautions related to cable ducting



## 2. .4.3: Step – Figure ‘8’ing

### Do

- Welcome and greet the participants. Revise the learning of the previous sessions and ask them if they have any doubts.

### Say

- Having understood in detail about aerial cabling - ducting process
- Let us now understand – figure ‘8’ing

### Do

- Share with the participants the various factors that one has to consider for figure‘8’ing
- Share with the participants the key steps of figure ‘8’ing process
- Share the related precautions with the participants

### Notes for Facilitation

- Facilitate the discussion and avoid arguments
- Discuss the various factors that help you consider during figure ‘8’ing
- Discuss the main aspects of figure ‘8’ing – make adjacent circles, putting cable from the payout trailers on these circles etc.
- Discuss with the participants the advantages of figure ‘8’ing
- Summarise with the help of page 57 of the participant’s hand book
- Conduct a quick quiz to test the participants understanding and move to the next section

### Demonstrate

- Organize the trip of these participants to an OFC installation site
- Discuss the main aspects of figure ‘8’ing – make adjacent circles, putting cable from the payout trailers on these circles etc.
- Demonstrate the various precautions related to figure ‘8’ing

## 2. .4.4: Step – Cable Pulling & Blowing

### Do

- Welcome and greet the participants. Revise the learning of the previous sessions and ask them if they have any doubts.

### Say

- Having understood in detail about figure '8'ing
- Let us now understand – cable pulling & blowing

### Do

- Share with the participants the various factors that one has to consider for cable pulling & blowing
- Share with the participants the key steps of cable pulling & blowing
- Share the related precautions with the participants

### Notes for Facilitation

- Facilitate the discussion and avoid arguments
- Discuss the various factors that help you consider during cable pulling & blowing
- Discuss the main aspects of cable pulling – duct with pull ropes, lubrication for pulling and correct way of pulling etc.
- Discuss the main aspects of cable blowing – motorized blower head; duct a one way valve etc.
- Summarise with the help of page 58-60 of the participant's hand book
- Conduct a quick quiz to test the participants understanding and move to the next section

### Demonstrate

- Organize the trip of these participants to an OFC installation site
- Discuss the main aspects of cable pulling & blowing
- Demonstrate the various precautions related to cable pulling & blowing

## 2. .4.5: Steps – OFC Termination Method

### Do

- Welcome and greet the participants. Revise the learning of the previous session and ask them if they have any doubts.

### Say

- Having understood in detail about cable pulling & blowing
- Let us now understand – OFC termination method

### Demonstrate

- Demonstrate the steps related to OFC termination
- Demonstrate the various safety precautions to be observed for OFC termination

### Steps: OFC Termination

**Step 1**– Put on a fiber boot.

**Step 2**– Measure 14 cm for striping as per specs.

**Step 3**– Strip the fiber using wire stripper.

**Step 4**– Use Alcohol wipes to clean any residue.

**Step 5**– Give the fiber a very slight bend.

**Step 6**– Put the fiber in cleaver holder at 10.5 cm mark (as per specs) and cleave the fiber.

**Step 7**– Put the fiber in the connector & squeeze holder.

**Step 8**– Slide the boot and the connection is complete.

### Summarize

- Summarize with the help of relevant facilitator's material. Refer to page 61 of the hand book

## 2. .5: Testing and Closing Activities

### Do

- Welcome and greet the participants. Revise the learning of the previous session and ask them if they have any doubts.

### Say

- Having understood in detail about OFC termination method
- Let us now understand – testing and closing activities

### Notes for Facilitation

- Facilitate the discussion and avoid arguments
- Discuss that after installation, splicing and termination of OFC it must be tested
- Discuss with participants that testing of OFC has to check – continuity & polarity, insertion loss etc.
- Discuss the precautions related to testing and closing activities
- Summarise with the help of page 61 of the participant's hand book
- Conduct a quick quiz to test the participants understanding and move to the next section

### Demonstrate

- Demonstrate the steps related to testing and closing activities
- Demonstrate the various precautions to be observed for testing and closing activities

## 2.5: Reporting and Documentation



- Welcome and greet the participants. Revise the learning of the previous session and ask them if they have any doubts.



- Having understood in detail about OFC termination method
- Let us now understand – testing and closing activities



- Facilitate the discussion and avoid arguments
- Discuss that after installation, splicing and termination of OFC it must be tested
- Discuss with participants that testing of OFC has to check – continuity & polarity, insertion loss etc.
- Discuss the precautions related to testing and closing activities
- Summarise with the help of page 61 of the participant's hand book
- Conduct a quick quiz to test the participants understanding and move to the next section



- Demonstrate the steps related to testing and closing activities
- Demonstrate the various precautions to be observed for testing and closing activities

## Answers to exercises for PHB

### Unit 2.2 Exercise

**Match the following (PAGE 36):**

1. (2) 2. (3) 3. (5) 4. (1) 5. (4)

### Unit 2.3 Fill in the blanks (PAGE 50)

1. Black work mat
2. Lab wipes
3. Polishing Pad - place under polishing film
4. Cable jacket stripper
5. Fiber optic Stripper

### Multiple Choice Questions (PAGE 84)

1. d 2. d 3. c 4. b 5. d 6. c 7. a 8. d 9. b 10. b 11. a 12. b 13. c and d 14. c and d

### True/False

15. True

### Descriptive

16. Refer Unit 2.1: Site visit and route inspection  
Topic - 2.1.2 Route inspection and its benefits
17. Refer Unit 2.1: Site visit and route inspection  
Topic - 2.1.2 Route inspection and its benefits
18. Refer Unit 2.1: Site visit and route inspection  
Topic - 2.1.3 (2.1.3.1,2.1.3.2, 2.1.3.3) Steps - Route inspection
19. Refer Unit 2.3: Fibre Optic Tools and Tool kit  
Topic - 2.3.1 Route inspection and its benefits
20. Refer Unit 2.3: Fibre Optic Tools and Tool kit  
Topic - 2.3.2 Fibre Optic Tools
21. Refer Unit 2.3: Fibre Optic Tools and Tool kit  
Topic - 2.3.2 Fibre Optic Tools
22. Refer Unit 1.1: Brief overview of Telecom & Fiber Optics  
Topic - 1.1.6 Optical Fiber Technology
23. Refer Unit 2.4: Installation of Fibre Optic Cable  
Topic - 2.4.1 Fiber optic Cable specifications - Tensile strength
24. Refer Unit 2.4: Installation of Fibre Optic Cable  
Topic - 2.4.1 Fiber optic Cable specifications - Tensile strength
25. Refer Unit 2.4: Installation of Fibre Optic Cable  
Topic - 2.4.2 Fiber optic Cable specifications - Bend radius
26. Refer Unit 2.4: Installation of Fibre Optic Cable  
Topic - 2.4.2 Fiber optic Cable specifications - Bend radius
27. Refer Unit 2.4: Installation of Fibre Optic Cable  
Topic - 2.4.11 Installation of Fibre Optic Cable

## Answers to exercises for PHB

28. Refer Unit 2.3: Fibre Optic Tools and Tool kit  
Topic - 2.3.3 Optical Power meter (OPM): A must for Fiber Cable testing

29. Refer Unit 2.4: Installation of fiber optic cable  
Topic - 2.4.11.2 Step - Ducting Process

30. Refer Unit 2.3: Fibre Optic Tools and Tool kit  
Topic 2.3.3 Optical Power meter (OPM): A must for Fiber Cable testing

31. Refer Unit 2.4: Installation of Fiber optic cable  
Topic - 2.4.4 Fiber Optic Cable specifications - Attenuation

32. Refer Unit 2.4: Installation of Fiber optic cable  
Topic - 2.4.4 Fiber Optic Cable specifications - Attenuation

33. Refer Unit 2.4: Installation of Fiber optic cable  
Topic - 2.4.5 Fiber Optic Cable Specifications - Continuity

34. Refer Unit 2.4: Installation of Fiber optic cable  
Topic - 2.4.5 Fiber Optic Cable Specifications - Continuity

35. Refer Unit 2.4: Installation of Fiber optic cable  
Topic - 2.4.10 Handling Optic Fiber cable

36. Refer Unit 2.4: Installation of Fiber optic cable  
Topic - 2.4.10 Handling Optic Fiber cable

37. Refer Unit 2.4: Installation of Fiber optic cable  
Topic - 2.4.10 Handling Optic Fiber cable

38. Refer Unit 2.4: Installation of Fiber optic cable  
Topic - 2.4.10 Handling Optic Fiber cable  
Topic - 2.4.11 Installation of Optical Fibre Cable

39. Refer Unit 2.4: Installation of Fiber optic cable  
Topic - 2.4.10 Handling Optic Fiber cable  
Topic - 2.4.11 Installation of Optical Fibre Cable

40. Refer Unit 2.4: Installation of Fiber optic cable  
Topic - 2.4.10 Handling Optic Fiber cable  
Topic - 2.4.11 Installation of Optical Fibre Cable

41. Refer Unit 2.4: Installation of Fiber optic cable  
Topic - 2.4.10 Handling Optic Fiber cable

42. Refer Unit 2.4: Installation of Fiber optic cable  
Topic - 2.4.10 Handling Optic Fiber cable

43. Refer Unit 2.4: Installation of Fiber optic cable  
Topic - 2.4.11 Steps - Optical Fiber Installation

44. Refer Unit 2.4: Installation of Fiber optic cable  
Topic - 2.4.11.1 Trending

## Answers to exercises for PHB

45. Refer Unit 2.4: Installation of Fiber optic cable  
Topic - 2.4.11.1 Trending

46. Refer Unit 2.4: Installation of fiber optic cable  
Topic - 2.4.11.1 Aerial cabling

47. Refer Unit 2.4: Installation of fiber optic cable  
Topic - 2.4.11.2 Ducting process

48. Refer Unit 2.4: Installation of fiber optic cable  
Topic - 2.4.11.2 Ducting process

49. Refer Unit 2.4: Installation of fiber optic cable  
Topic - 2.4.11.4 Cable Pulling & Blowing

50. Refer Unit 2.4: Installation of fiber optic cable  
Topic - 2.4.11.4 Cable Pulling & Blowing

51. Refer Unit 2.4: Installation of fiber optic cable  
Topic - 2.4.11.5 Step - OFC Termination Method







**Skill India**  
कौशल भारत - कुशल भारत



सत्यमेव जयते  
GOVERNMENT OF INDIA  
MINISTRY OF SKILL DEVELOPMENT  
& ENTREPRENEURSHIP



N · S · D · C  
National  
Skill Development  
Corporation

Transforming the skill landscape



# Perform planned maintenance and Repair activities

Unit 3.1 – Carry out testing of optical fiber

Unit 3.2 – Carry out splicing of optical fiber

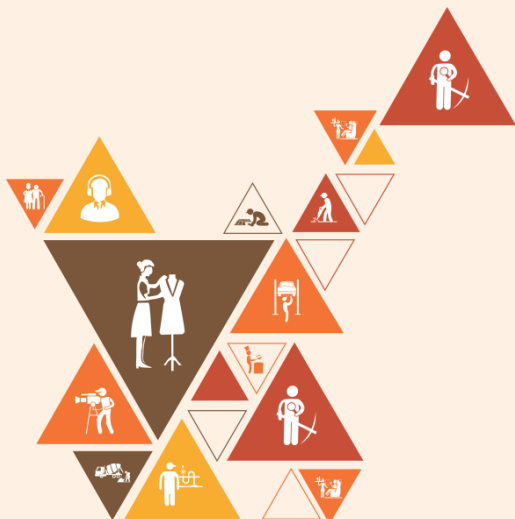

TEL/N6403

## Key Learning Outcomes

**At the end of this module, student you will be able to:**

1. Explain and perform tests on OFC for continuity, insertion loss and troubleshooting
2. Explain and perform tests on OFC using optical inspection microscope
3. Explain and perform tests on OFC using OTDR
4. Explain and perform test on OFC using visual fault locator
5. Explain and perform bare fiber testing
6. Describe splicing its purpose and its benefits
7. Describe and demonstrate mechanical and fusion splicing

## UNIT 3.1: Testing Optical Fiber Cable

### Unit Objectives



**At the end of this unit, student will be able to:**

1. Explain and outline the reasons for testing optical fiber cable
2. Explain and perform different types of tests – optical microscope inspection
3. Explain and perform tests using visual fault locator
4. Explain and perform bare fiber test using OTDR

### Notes for Facilitation



- You could ask the students why testing of fiber cable is necessary on ground.
- Also ask the student why different types of testing is required for different types of cable.
- Encourage shy students to provide information about themselves and ask them to read the paragraph and explain what they have understood.
- Perform live testing of cable via OTDR
- Give students some time to think and discuss amongst themselves.
- Set the context before explaining to them in detail about testing of fiber cable.

## UNIT 3.1.1: Testing Optical Fiber Cable

### Ask

- Ask the students about their understanding of fiber cables and its testing
- Ask the students why testing of fiber cable is required and is it important

### Say

- Having understood the importance of testing optical fiber cable, it's time to discuss the procedure, how to test the optical fiber cable.
- However, the first thing that we will start testing the fiber in the lab then will test it on ground.

### Resources to be Used

- Explain and showcase each tool required for testing the fiber cable such as visual fault locator, OTDR, connector, red laser light and other essential tools.

### Notes for Facilitation

- Facilitate the discussion and avoid arguments
- Discuss the positioning of various parts and sections in detail
- Summaries with the help of relevant materials.
- Conduct a quick quiz to test the participants understanding and move on to the next section

### Demonstrate

- Plan a visit for the students, to an actual site where an optical fiber cable testing is happening
- Demonstrate the various components of the site visit in detail
- Demonstrate the benefits of testing

### 3.1.1.1: Testing Optical Fiber Visual Fault Locator

#### Ask

- Ask the students about their understanding on visual fault locator (VFL)
- Ask the students why it's important to use VFL.

#### Say

- In this session, we would learn about the steps involved in testing fiber via visual fault locator.
- However, the first thing that we will start testing the fiber in the lab then will test it on ground.

#### Notes for Facilitation

- Facilitate the discussion and avoid arguments
- Discuss the positioning of various parts and sections in detail
- Summaries with the help of relevant materials/steps involved in performing.
- Conduct a quick quiz to test the participants understanding and move on to the next section

#### Demonstrate

- Plan a visit for the students, to an actual site where an optical fiber cable testing via VFL is happening
- Demonstrate the various components of the site visit in detail
- Demonstrate the benefits of using VFL

### 3.1.1.2: Testing OFC – Inspection Microscope

#### Ask

- Ask the students about their understanding on Inspection Microscope
- Ask the students why Inspection Microscope is used.

#### Say

- In this session, we would learn about the steps involved in testing fiber via visual connector inspection.

#### Resources to be Used

- Explain and showcase each tool required for testing the fiber cable via inspection microscope.
- Tools required for ‘Visual Connector Inspection’
  - Fiber Inspection Microscope and Adaptors
  - Cleaning Swabs
  - Adaptor Inspection tools
  - Typical Universal Adaptor

#### Steps: Visual Connector Inspection

**Step1** - Inspect the connector with microscope

**Step2** - Observe the connector end

**Step3** - Clean the connector

#### Notes for Facilitation

- Facilitate the discussion and avoid arguments
- Discuss the positioning of various parts and sections in detail
- Summaries with the help of relevant materials/demonstration.
- Conduct a quick quiz to test the participants understanding and move on to the next section

#### Demonstrate

- Plan a visit for the students, to an actual site where testing of optical fiber cable via visual connector microscope is happening
- Demonstrate the various components of the site visit in detail and its benefits

### 3.1.1.3: Testing OFC – Connector End Cleaning Procedure

#### Ask

- Ask the students about their understanding why cleaning of connector is important

#### Say

- In this session, we would learn about the steps involved in cleaning the connector
- Observe what is happening on the site (during the site visit)

#### Resources to be Used

- Explain and showcase each tool required for cleaning the connector of an optical fiber cable.
- Tools required for 'Cleaning the Connector'
  - Dust caps on connectors, bulkhead splices, patch panels, or anything that is going to have a connection made with it.
  - lint-free pads and isopropyl alcohol to clean the connectors and many more.

#### Notes for Facilitation

- Facilitate the discussion and avoid arguments
- Discuss the positioning of various parts and sections in detail
- Summaries with the help of relevant materials/steps involved in performing.
- Conduct a quick quiz to test the participants understanding and move on to the next section

#### Demonstrate

- Plan a visit for the students, to an actual site where cleaning of connector take place
- Demonstrate the various components on the site visit in details



### 3.1.1.4: Tools – Bare Fiber Test

#### Ask

- Ask the students about their understanding on different types of tools used for testing

#### Say

- In this session, we would learn about different types of tools used while performing bare fiber testing.

#### Resources to be Used

- Explain and showcase each tool required for bare fiber testing.

#### Steps: Bare Fiber Test

**Step 1** - Inspect the cable and record any visible signs of defects.

**Step 2** - Strip at least 2 ft. of cable end, clean and strip the fibers.

**Step 3** - Connect the fiber using a bare fiber adapter to an OTDR through a patch cord.

**Step 4** – Start the OTDR and select the correct wavelength and refractive index for the test. Print and record the OTDR traces on disk. Indicate direction of measurement and loose tube - fiber color.

**Step 5** - Compare the test results to the manufacturer’s specifications.

**Step 6** - Remove bare fiber adapter and cut off excess fiber from the cable end.

**Step 7** - Install heat shrink / protective covering to the cable end to prevent the entry of moisture or other contaminants.

#### Notes for Facilitation

- Facilitate the discussion and avoid arguments
- Discuss the positioning of various parts and sections in detail
- Summaries with the help of relevant materials/demonstration.
- Conduct a quick quiz to test the participants understanding and move on to the next section

#### Demonstrate

- Plan a visit for the students, to an actual site where bare fiber testing is happening
- Demonstrate the various components of the site visit in detail and its benefits

### 3.1.1.5: About OTDR

#### Ask

- Ask the students about their understanding on OTDR machine
- Ask the student why its required and why we use OTDR machine

#### Say

- In this session, we would learn about OTDR
- In this session, we would learn about the importance of OTDR and its benefits

#### Notes for Facilitation

- Facilitate the discussion and avoid arguments
- Discuss the positioning of various parts and sections in detail
- Summaries with the help of relevant materials/steps involved in performing.
- Conduct a quick quiz to test the participants understanding and move on to the next section

#### Demonstrate

- Plan a visit for the students, to an actual site where OTDR machine is been used
- Demonstrate the various components on the site visit in details.

### 3.1.1.6: Insertion Loss Test

#### Ask

- Ask the students about their understanding on insertion loss
- Ask the student why its required and why testing of insertion loss is done

#### Say

- In this session, we would learn about insertion loss
- In this session, we would learn about the tools used to measure insertion loss

#### Resources to be Used

- Explain and showcase each tool required for measuring insertion loss.

#### Steps: Insertion Loss Test

**Step 1** - Connector end-faces are to be inspected and cleaned (alcohol wipes) prior to mating with through adapters.

**Step 2** - Set-up light source, power meter e.g., adapters, power supply, data entry, etc. (Please note this equipment requires warm up time for stabilization).

**Steps 3** - Setup “launch cable” for calibration before actual tests.

**Step 4** - Connect actual leads to the “launch cable” in order check loss at one end.

**Step 5** - Connect the third lead to the” launch cable” and the actual lead to check the loss at the other end.

#### Notes for Facilitation

- Facilitate the discussion and avoid arguments
- Discuss the positioning of various parts and sections in detail
- Summaries with the help of relevant materials/steps involved in performing.
- Conduct a quick quiz to test the participants understanding and move on to the next section

#### Demonstrate

- Plan a visit for the students, to an actual site where measurement of insertion loss test take place
- Demonstrate the various components on the site visit in detail.

### 3.1.1.7: Optical Return Loss

#### Ask

- Ask the students about their understanding on optical return loss
- Ask the student why its required to learn about optical return loss

#### Say

- In this session, we would learn about optical return loss
- In this session, we would learn about the tools used to measure optical return loss

#### Resources to be Used

- Explain and showcase each tool required for measuring optical return loss.

#### Steps: Optical Return Loss Test

**Step 1-** Optical Reference Loss (ORL) referencing: measure the output power level at the fiber jumper using a separate power meter.

**Step 2-** Measure the ORL of the front connector (jumper to test equipment connection). Requires use of connectors.

**Step 4-** Connect to the fiber under test:

- o ORL is measured in dB and is a positive value.
- o Higher the number, smaller the reflection – yielding the desired result.
- o ORL is most commonly measured at 1310, 1550 and 1625nm single-mode wavelength.

#### Notes for Facilitation

- Facilitate the discussion and avoid arguments
- Discuss the positioning of various parts and sections in detail
- Summaries with the help of relevant materials/steps involved in performing.
- Conduct a quick quiz to test the participants understanding and move on to the next section

#### Demonstrate

- Plan a visit for the students, to an actual site where testing of optical return loss take place
- Demonstrate the various components on the site visit in detail.

### 3.1.1.8: Miscellaneous Test

#### Ask

- Ask the students about different kind of miscellaneous test conducted on fiber cable.

#### Say

- In this session, we would learn about various kind of miscellaneous test.

#### Notes for Facilitation

- Facilitate the discussion and avoid arguments
- Summaries with the help of relevant materials/steps involved in performing.
- Conduct a quick quiz to test the participants understanding and move on to the next section

#### Demonstrate

- Plan a visit for the students, to an actual site where testing of optical return loss take place
- Demonstrate the various components on the site visit in detail.

## UNIT 3.2: Optical Fiber Splicing

### Unit Objectives

**At the end of this unit, students will be able to:**

1. Explain and outline optical fiber splicing
2. Explain and outline the reasons for splicing
3. Explain and outline types of optical fiber splicing
4. Explain and perform mechanical as well as fusion splicing
5. Describe and demonstrate effective safety norms during splicing

### Notes for Facilitation

- You could ask the students why splicing of fiber cable is necessary.
- Also ask the student how many types of splicing can be done.
- Encourage shy students to provide information about themselves and ask them to read the paragraph and explain what they have understood.
- Perform live mechanical splicing as well as fusion splicing
- Give students some time to think and discuss amongst themselves.
- Set the context before explaining to them in detail about splicing process.

### 3.2.1: Optical Fiber

#### Ask

- Ask the students about their understanding on splicing.

#### Say

- In this session, we would learn about splicing
- Observe what is happening on the site (during the site visit)

#### Notes for Facilitation

- Facilitate the discussion and avoid arguments
- Summaries with the help of relevant materials.
- Conduct a quick quiz to test the participants understanding and move on to the next section

### 3.2.2: Reason for Optical Fiber Splicing

#### Ask

- Ask the students why optical fiber splicing is done.

#### Say

- In this session, we would learn about splicing and why it is done
- Observe what is happening on the site (during the site visit)

#### Notes for Facilitation

- Facilitate the discussion and avoid arguments
- Summaries with the help of relevant materials.
- Conduct a quick quiz to test the participants understanding and move on to the next section

### 3.2.3: Types of Optical Fiber Splicer

#### Ask

- Ask the students about two types of splicer and their difference

#### Say

- In this session, we would learn about two types of splicing
- In this session, we would learn about the tools used while splicing.

#### Notes for Facilitation

- Facilitate the discussion and avoid arguments
- Summaries with the help of relevant materials/steps involved in performing.
- Conduct a quick quiz to test the participants understanding and move on to the next section

#### Demonstrate

- Plan a visit for the students, to an actual site where splicing take place
- Demonstrate the various components on the site visit in detail.

### 3.2.4.1: Cable Preparation for Splicing

#### Ask

- Ask the students what all is required/equipment's before performing splicing

#### Say

- In this session, we would learn/prepare check list before performing splicing

#### Notes for Facilitation

- Facilitate the discussion and avoid arguments
- Summaries with the help of relevant materials.
- Conduct a quick quiz to test the participants understanding and move on to the next section



### 3.2.4.2: Material and Equipment Used for Splicing

#### Ask

- Ask the students what all equipment's required before performing splicing

#### Say

- In this session, we would learn about material and equipment used for splicing

#### Resources to be Used

- Explain and showcase each tool required for splicing of optical cable.

#### Notes for Facilitation

- Facilitate the discussion and avoid arguments
- Discuss the positioning of various parts/components and sections in detail
- Summaries with the help of relevant materials/steps involved in performing.
- Conduct a quick quiz to test the participants understanding and move on to the next section

### 3.2.4.3: Mechanical Splicing Preparation

#### Ask

- Ask the students about the process of mechanical splicing

#### Say

- In this session, we would learn how to perform mechanical splicing

#### Resources to be Used

- Explain and showcase each tool required for splicing.

#### Steps: Mechanical Splicing Preparation

**Step 1-** a. Strip the fiber, b. Cleave the fiber, c. Clean the fiber

**Step 2-** insert fiber to the right side of the mechanical splice and push fiber to the end

**Step 3-** lock the right arm to fix the fiber

**Step 4 –** repeat step 2 for another fiber insert to left side of mechanical splice and push the fiber to the end

**Step 5 –** form a curve on the left curve.

**Step 6 –** press both MS buttons completely during the left fiber is curving for connecting fibers

**Step 7 –** unlock the right arm

**Step 8 –** splicing is done

#### Notes for Facilitation

- Facilitate the discussion and avoid arguments
- Discuss the positioning of various parts/component and sections in detail
- Summaries with the help of relevant materials/steps involved in performing.
- Conduct a quick quiz to test the participants understanding and move on to the next section

#### Demonstrate

- Plan a visit for the students, to an actual site where splicing take place
- Demonstrate the various components on the site visit in detail.

### 3.2.4.4: Fusion Splicing

#### Ask

- Ask the students about the last session/chapter on mechanical splicing are there any doubt to be addressed,

#### Say

- In this session, we would learn how to perform fusion splicing

#### Resources to be Used

- Explain and showcase each tool required for splicing.

#### Steps: Mechanical Splicing Preparation

##### Step 1-

- Strip the fiber
- Cleave the fiber
- Clean the fiber

**Step 2-** place each fiber into the guides in the fusion splicing machine and clamp it in places. (keep the fiber close to the electrodes)

##### Step 3-

- Choose the proper program for the fiber type being spliced.
- Splicer will show the fiber being spliced on a video screen.
- Fiber ends will be inspected for proper cleaves and bad ones will be rejected.
- Rejected fiber must be cleaved again.
- Fiber will be moved into position, perfused to remove any dirt on the fiber ends and preheat the fiber for splicing.
- Fiber will be aligned using the core alignment method used on the splicer.
- Fiber will be fused by an automatic arc cycle that heats them in an electric arc and feeds the fibers together at a controlled rate.

**Step 4-** on completion, the splicing machine will inspect the splice and estimate the optical loss of the splice. It will tell the operator if a splice need to be remade.

**Step 5 –** the operator removes the fibers from the guides and attaches a permanent splice protector by heat -shrinking or clamping clam shell protectors.

## Notes for Facilitation

- Facilitate the discussion and avoid arguments
- Discuss the positioning of various parts/component and sections in detail
- Summaries with the help of relevant materials/steps involved in performing.
- Conduct a quick quiz to test the participants understanding and move on to the next section

## Demonstrate

- Plan a visit for the students, to an actual site where splicing take place
- Demonstrate the various components on the site visit in detail.

### 3.2.4.5: Protection

#### Ask

- Ask the students what they have learned from the previous session

#### Say

- In this session, we would understand the importance of protection while performing splicing.

## Notes for Facilitation

- Facilitate the discussion and avoid arguments
- Discuss the positioning of various parts/components and sections in detail
- Summaries with the help of relevant materials/steps involved in performing.
- Conduct a quick quiz to test the participants understanding and move on to the next section

## 3.2.5: Splicing Safety – Norms and Rules

### Say

- In this session, we would understand the importance of safety norms while performing splicing.

### Notes for Facilitation

- Facilitate the discussion and avoid arguments
- Discuss the positioning of various parts/components and sections in detail
- Summaries with the help of relevant materials/steps involved in performing.
- Conduct a quick quiz to test the participants understanding and move on to the next section

### Demonstrate

- Plan a visit for the students, to an actual site where safety norms are being addressed
- Demonstrate the various components on the site visit in detail.

## Answers to exercises for PHB

### Fill in the blanks (PAGE 85)

1. power in an optical signal
2. natural and artificial
3. Visual fault locator
4. Optical Time Domain Reflectometer

Fiber Splicing

### Multiple Choice Questions

a 2. a 3. a 4. b 5. b 6. c 7.b 8. b 9. a 10 All are important

### Descriptive

11. Refer Unit 3.1: Testing Optical Fiber Cable  
Topic 3.1.1 Testing Optical Fiber

12. Refer Unit 3.2 : Optical Fibre Splicing  
Topic 3.2.4.1 Cable preparation for splicing

13. Network speed, throughput,download speed, Jitter and delays

14. Refer Unit 3.1: Testing Optical Fiber Cable  
Topic 3.1.1 Testing Optical Fiber

15. Refer Unit 3.1: Testing Optical Fiber Cable  
Topic 3.1.1 Testing Optical Fiber

16. Unit 3.1: Testing Optical Fiber Cable  
Topic 3.1.1.1 Testing Optical Fibre Visual Fault Locator

17. Unit 3.1: Testing Optical Fiber Cable  
Topic 3.1.1.1 Testing Optical Fibre Visual Fault Locator

18. Unit 3.1: Testing Optical Fiber Cable  
Topic 3.1.1.1 Testing Optical Fibre Visual Fault Locator

19. Unit 3.1: Testing Optical Fiber Cable  
Topic 3.1.1.2 Testing Optical Cable - Inspection  
Microscope

20. Unit 3.1: Testing Optical Fiber Cable  
Topic 3.1.1.2 Steps - Visual Connector Inspection

21. Unit 3.1: Testing Optical Fiber Cable  
Topic 3.1.1.2 Steps - Visual Connector Inspection

22. Unit 3.1: Testing Optical Fiber Cable  
Topic 3.1.1.3 Testing Optical Fibre Cable - Connector end  
cleaning procedure

23. Unit 3.1: Testing Optical Fiber Cable  
Topic 3.1.1.2 Testing Optical Cable - Inspection  
Microscope

## Answers to exercises for PHB

24. Unit 3.1: Testing Optical Fiber Cable  
Topic 3.1.1.2 Steps - Visual Connector Inspection
25. Refer Unit 3.1 : Testing Optical Fiber Cable  
Topic 3.1.1.3 Tools- Bare Fibre Test  
Topic 3.1.1.4 Steps - Bare Fibre Test
26. Refer Unit 3.1 : Testing Optical Fiber Cable  
Topic 3.1.1.3 Tools- Bare Fibre Test  
Topic 3.1.1.4 Steps - Bare Fibre Test
27. Refer Unit 3.1 : Testing Optical Fiber Cable  
Topic 3.1.1.3 Tools- Bare Fibre Test  
Topic 3.1.1.4 Steps - Bare Fibre Test
28. Refer Unit 3.1 : Testing Optical Fiber Cable  
Topic 3.1.1.6 Insertion loss Test
29. Refer Unit 3.1 : Testing Optical Fiber Cable  
Topic 3.1.1.6 Insertion loss Test
30. Refer Unit 3.1 : Testing Optical Fiber Cable  
Topic 3.1.1.6 Insertion loss Test
31. 28. Refer Unit 3.1 : Testing Optical Fiber Cable  
Topic 3.1.1.7 Optical Return loss
32. Refer Unit 3.1 : Testing Optical Fiber Cable  
Topic 3.1.1.1 Testing Optical Fiber - Visual Fault Locator
33. Refer Unit 3.1 : Testing Optical Fiber Cable  
Topic 3.1.1.5 About OTDR
34. Refer Unit 3.2 : Optical Fiber Splicing  
Topic 3.2 Optical Fiber Splicing
35. Refer Unit 3.2 : Optical Fiber Splicing  
Topic 3.2.3 Types of Optical Fibre Splicing
36. Refer Unit 3.2 : Optical Fiber Splicing  
Topic 3.2.3 Types of Optical Fibre Splicing
37. Refer Unit 3.2 : Optical Fiber Splicing  
Topic 3.2.4.1 Cable preparation for Splicing
38. Refer Unit 3.2 : Optical Fiber Splicing  
Topic 3.2.4.4 Mechanical Splicing
39. Refer Unit 3.2 : Optical Fiber Splicing  
Topic 3.2.4.3 Fusion Splicing
40. Refer Unit 3.2 : Optical Fiber Splicing  
Topic 3.2.4.2 Material and Tools for Splicing







**Skill India**  
कौशल भारत - कुशल भारत



सत्यमेव जयते  
GOVERNMENT OF INDIA  
MINISTRY OF SKILL DEVELOPMENT  
& ENTREPRENEURSHIP



N · S · D · C  
National  
Skill Development  
Corporation

Transforming the skill landscape



# Perform corrective maintenance Activities

Unit 4.1 – Fault notification

Unit 4.2 – Fault localization and restoration

Unit 4.3 – Preventive and corrective maintenance

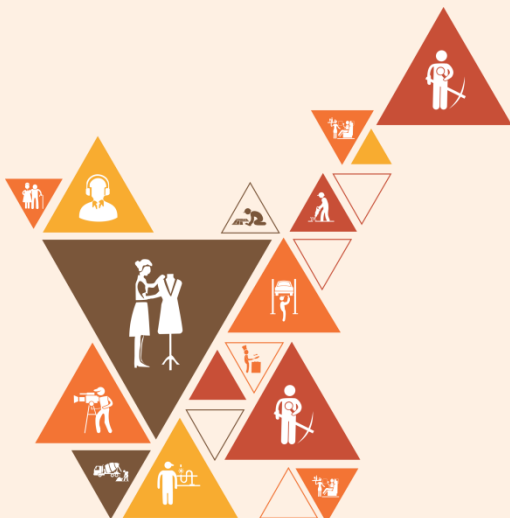

TEL/N6404

## Key Learning Outcomes

**At the end of this module, students will be able to:**

1. Explain, outline and demonstrate NOC fault notifications process
2. Demonstrate effective response to faults received from customer and contractor
3. Describe, demonstrate and monitor steps to fault localization and rectification
4. Explain and outline typical faults and demonstrate problem identification process
5. Perform effective optical fiber restoration process
6. Describe and demonstrate various work instructions
7. Perform effective corrective and preventive maintenance as per defined process
8. Demonstrate effective reporting and documentation skills

## UNIT 4.1: Fault Notification

### Unit Objectives

**At the end of this unit, students will be able to:**

1. Describe fault notification
2. Describe and demonstrate the process of receiving fault notification at NOC
3. Describe and demonstrate fault notification process

### Notes for Facilitation

- You could ask the students why fault notification is important
- Also ask the student what is the process of receiving fault notification from the NOC and demonstrate the process of fault notification.
- Encourage shy students to provide information about themselves and ask them to read the paragraph and explain what they have understood.

### 4.1.1: Fault Notification



- In this session, you will learn how to gather information from NOC team when a fault is occurred in the network of optical fiber



- Facilitate the discussion and avoid arguments
- Discuss the various ways to gather the information from the NOC team and others.
- Summaries with the help of relevant materials

### 4.1.2: Process for Receiving Fault Notification



- Ask the students about the last session/chapter on fault notification



- In this session, we would learn how to receive fault notification



**Step 1** - An operator zooms in from a macro view to the area of concern. Transceiver detects a fiber fault between a hub and one of the points (sometimes called a spoke).

**Step 2** - The operator is immediately notified about the fault's approximate location as depicted in 'Red'. Operator acknowledges the fault and relays information to the network operations team of the area.

**Step 3** - Once the fault has been fixed, information from the 'Network Team' is relayed back to the operator who then closes the issue.



- Facilitate the discussion and avoid arguments
- Discuss the process in detail.
- Summaries with the help of relevant materials

## Demonstrate



- Demonstrate the process of receiving a fault notification from the NOC team in the classroom via role play.

### 4.1.3: Fault Notification Guideline

## Ask



- Ask the students about the last session/chapter on fault notification

## Say



- In this session, we would be learning the norms stated by the company/standard set internationally.

## Notes for Facilitation



- Facilitate the discussion and avoid arguments
- Discuss the process in detail.
- Summaries with the help of relevant materials

## 4.1.4: Fault Notification Process

### Ask

- Ask the students about the last session on fault notification guideline

### Say

- In this session, we would be learning the process of fault notification

### Steps: Process of Fault Notification

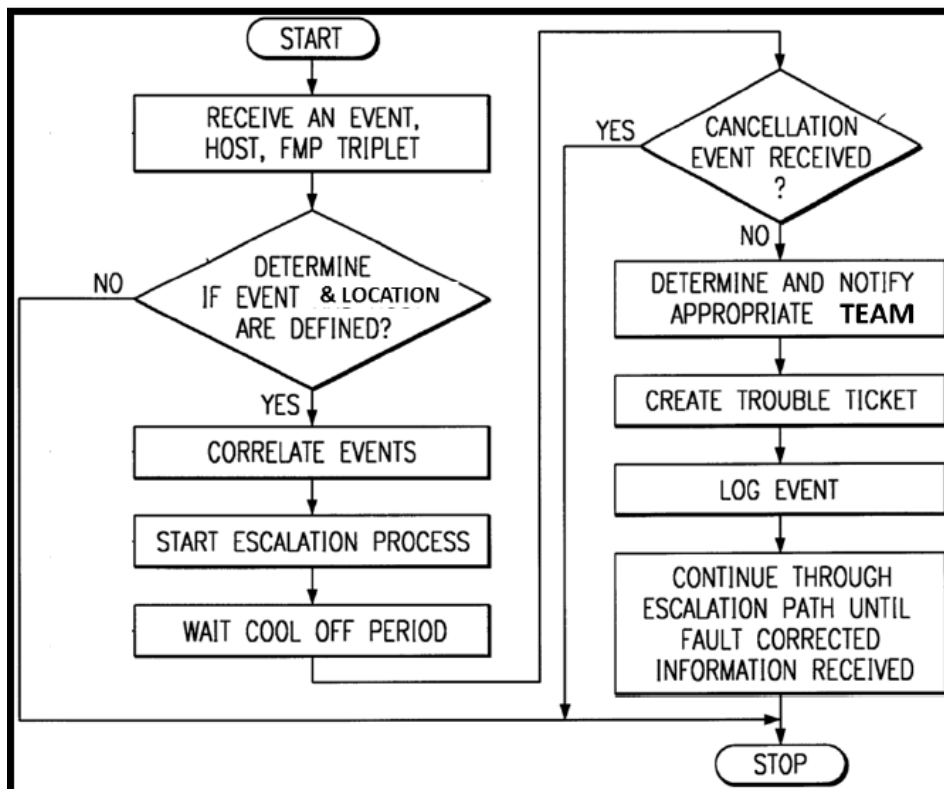

### Notes for Facilitation

- Facilitate the discussion and avoid arguments
- Discuss the process in detail.
- Summaries with the help of relevant materials

## UNIT 4.2: Fault Localization and Restoration

### Unit Objectives

**At the end of this unit, students will be able to:**

1. Explain and outline fault localization and rectification
2. Explain, outline and follow the steps related to fault localization and rectification
3. Explain and outline typical cable system faults
4. Explain, outline and follow problem identification flowchart
5. Prepare for fault localization and restoration
6. Describe and demonstrate OFC restoration process
7. Describe and demonstrate various work instructions

### Notes for Facilitation

- You could ask the students why fault localization and restoration is important
- Also ask the student what is the process or steps related to fault localization and rectification demonstrate the process of fault notification.
- Encourage shy students to provide information about themselves and ask them to read the paragraph and explain what they have understood.

## 4.2.1: Fault Localization and Restoration

### Say

- In this session, you will learn how to identify the fault at the specific location and restore it.

### Notes for Facilitation

- Discuss the process of identifying the fault at various location and restore process
- Summaries with the help of relevant materials

### Steps: Fault Localization and Restoration

Step 1 – Identify failed module

Step 2 – Identify module sub-system

Step 3 – Identify failed element

Step 4 – Fault located (Fault localization)

Step 5 – Check previous actions

Step 6 – Establish recovery actions (Fault Restoration)

Step 7 – Initiate failure recovery (Fault Restoration)

Step 8 – Fault removed

### Notes for Facilitation

- Facilitate the discussion and avoid arguments
- Discuss the process in detail.
- Summaries with the help of relevant materials

### Demonstrate

- Plan a visit for the students, to an actual site where fault is being localized and restoration is done
- Demonstrate the various components on the site visit in detail.



## 4.2.2: Cable System Faults

### Do

- Welcome and greet the participants. Revise the learning of the previous sessions and ask them if they have any doubts on fault localization and restoration.

### Say

- In this session, we would be learning about different types of fault occur in a cable (fiber)

### Notes for Facilitation

- Facilitate the discussion and avoid arguments
- Discuss the process in detail on cable system faults.
- Summaries with the help of relevant materials

## 4.2.3: Problem Identification Flowchart

### Do

- Welcome and greet the participants. Revise the learning of the previous sessions and ask them if they have any doubts on cable system fault.

### Say

- In this session, we would be learning how to identify the problem in the cable network (fiber)

### Steps: Problem Identification Flowchart

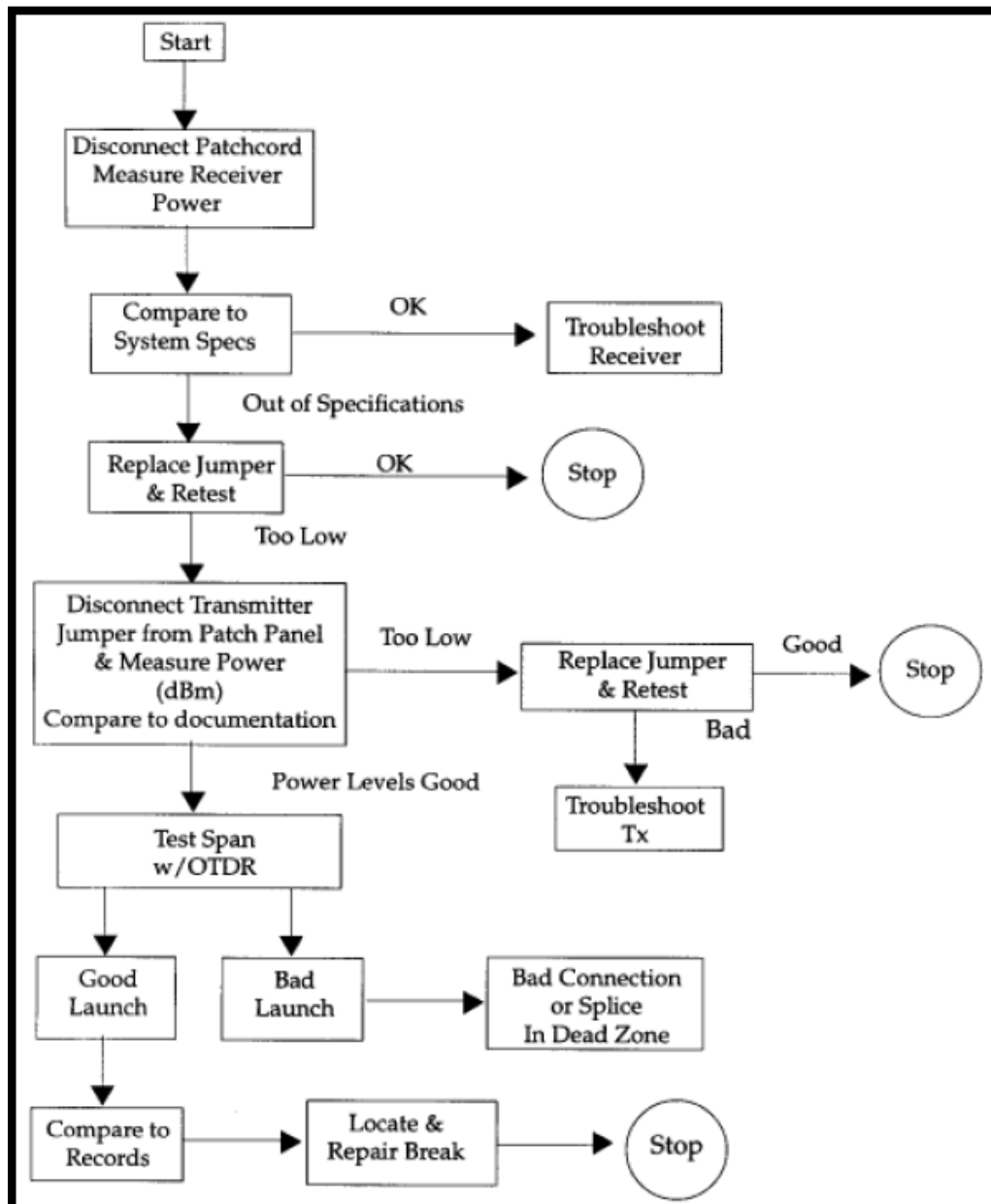

## Notes for Facilitation

- Facilitate the discussion and avoid arguments
- Discuss the process in detail on problem identification.
- Summaries with the help of relevant materials

### 4.2.4: Preparing for Fault Rectification

#### Do

- Welcome and greet the participants. Revise the learning of the previous sessions and ask them if they have any doubts on problem identification flowchart

#### Say

- In this session, we would be learning how to prepare for fault rectification

#### Do

- Before performing fault, rectification following points need to be addressed like is the fault is interrupting the service, how long is the route, what sought of fault locator is readily available
- Understand various challenges faced during the process of rectification and instruments which are important to be used during the process.

## Notes for Facilitation

- Facilitate the discussion and avoid arguments
- Discuss the process in detail about the challenges faced during the process and instrument required for rectification.
- Summaries with the help of relevant materials/examples

## Demonstrate

- Plan a visit for the students, to an actual site where fault rectification take place
- Demonstrate the various components/instrument used on the site visit in detail.

## 4.2.5: OFC Restoration Process

### Do

- Welcome and greet the participants. Revise the learning of the previous sessions and ask them if they have any doubts on prepare for fault rectification.

### Say

- In this session, we would be learning how an OFC restoration process take place.

### Do

- Before performing OFC cut restoration process depend on various parameters which need to be explained in detail

### Demonstrate

- Plan a visit for the students, to an actual site where OFC restoration take place
- Demonstrate the various components/instrument used on the site visit in detail.

### Notes for Facilitation

- Facilitate the discussion and avoid arguments
- Discuss the process in detail about the challenges faced during the process and instrument required for rectification.
- Share with the students the impact on the fibre optic cable
- Summaries with the help of relevant materials/examples

## 4.2.6: Working Instruction

### Do

- Welcome and greet the participants. Revise the learning of the previous sessions and ask them if they have any doubts.

### Say

- In this session, we would be learning working instruction for better quality and enhanced efficiency.

### Do

- Share the related following parameters how to function/ rout plan when you are operating o ground
- Mobilization plan, travelling plan, localization plan and OTDR trace measurement process.

### Demonstrate

- Demonstrate the various components/instrument used on the site visit in detail.

### Notes for Facilitation

- Facilitate the discussion and avoid arguments
- Discuss the process in detail about the challenges faced during the process and instrument required for rectification.
- Share with the students the impact on work ethics

## UNIT 4.3: Preventive and Corrective Maintenance

### Unit Objectives

**At the end of this unit, students will be able to:**

1. Describe maintenance
2. Describe and demonstrate corrective maintenance process
3. Explain, outline and fill corrective action report (reporting & documentation)
4. Describe and demonstrate the preventive maintenance process
5. Explain, outline and fill the preventive maintenance sheet (reporting & documentation)
6. Describe and demonstrate planned outage sub-process
7. Describe and demonstrate spare management process
8. Describe and demonstrate the related work instructions

### Notes for Facilitation

- Discuss and explain the about maintenance of a fiber and the network
- Explain and demonstrate the corrective maintenance process
- Explain and demonstrate the preventive maintenance process
- Explain the outline of fill the corrective action report (reporting & documentation)
- Explain the outline of fill the preventive maintenance sheet (reporting & documentation)
- How to plan outage sub-process, spare management process and related work instruction
- Encourage shy students to provide information about themselves and ask them to read the paragraph and explain what they have understood.

## 4.3.1: Maintenance

### Do

- Welcome and greet the participants. Revise the learning of the previous sessions and ask them if they have any doubts.

### Say

- In this session, we would be learning about OFC maintenance on the cable routes to prevent OFC damage & disruption.

### Do

- Explain two types of maintenance preventive and corrective in detail.

### Notes for Facilitation

- Facilitate the discussion and avoid arguments
- Discuss the maintenance activities and differentiate between preventive and corrective maintenance.

## 4.3.2: Corrective Maintenance Process

### Do

- Welcome and greet the participants. Revise the learning of the previous sessions and ask them if they have any doubts on maintenance.

### Say

- In this session, we would be learning about corrective maintenance process.

### Do

- Share with the participants the process of corrective maintenance on fiber cable
- Share the related precautions with the participants

### Notes for Facilitation

- Facilitate the discussion and avoid arguments
- Discuss the various steps involved in corrective maintenance in detail
- Assign the various teams presentation topics, and ask them to present the same
- Summaries with the help of page 141 of the participant's hand book
- Conduct a quick quiz to test the participants understanding and move to the next section

### Demonstrate

- Plan a visit for the students, to an actual site where corrective maintenance process take place
- Demonstrate the various components/instrument used on the site visit in detail.



### 4.3.3: Documentation – Corrective Action Report

#### Do

- Welcome and greet the participants. Review the learning of the previous sessions and ask them if they have any doubts on corrective maintenance process.

#### Say

- In this session, we would be learning how to prepare corrective action report.

#### Do

- Share with the participants the template of corrective action report
- Explain how to file the report

#### Notes for Facilitation

- Facilitate the discussion and avoid arguments
- Discuss the various steps involved in corrective maintenance in detail
- Assign the various teams presentation topics, and ask them to present the same
- Summaries with the help of page 142 of the participant's hand book
- Conduct a quick quiz to test the participants understanding and move to the next section

#### Demonstrate

- How to fill the corrective action report

### 4.3.4: Preventive Maintenance Process

#### Do

- Welcome and greet the participants. Revise the learning of the previous sessions and ask them if they have any doubts on corrective action report.

#### Say

- In this session, we would be learning about preventive maintenance process.

#### Do

- Share with the participants the process of Preventive maintenance on fiber cable
- Share the related precautions with the participants

#### Notes for Facilitation

- Facilitate the discussion and avoid arguments
- Discuss the various steps involved in preventive maintenance in detail
- Assign the various teams presentation topics, and ask them to present the same
- Summaries with the help of page 143 of the participant's hand book
- Conduct a quick quiz to test the participants understanding and move to the next section

#### Demonstrate

- Plan a visit for the students, to an actual site where preventive maintenance process take place
- Demonstrate the various components/instrument used on the site visit in detail.

## 4.3.5: Reporting - Preventive Maintenance Sheet

### Do

- Welcome and greet the participants. Review the learning of the previous sessions and ask them if they have any doubts on preventive maintenance process.

### Say

- In this session, we would be learning how to prepare preventive maintenance sheet.

### Do

- Share with the participants the template of preventive maintenance sheet
- Explain how to file the report

### Notes for Facilitation

- Facilitate the discussion and avoid arguments
- Assign the various teams presentation topics, and ask them to present the same
- Summaries with the help of page 144 of the participant's hand book
- Conduct a quick quiz to test the participants understanding and move to the next section

### Demonstrate

- How to fill the preventive maintenance sheet

### 4.3.6: Planned Outage Sub – Process

#### Do

- Welcome and greet the participants. Revise the learning of the previous sessions and ask them if they have any doubts on report preparation on preventive maintenance sheet.

#### Say

- In this session, we would be learning how to plan outage.

#### Do

- Share with the participants the outage plan for every sub- process

#### Notes for Facilitation

- Facilitate the discussion and avoid arguments
- Discuss the various steps involved in planning an outage in detail
- Assign the various teams presentation topics, and ask them to present the same
- Summaries with the help of page 145 of the participant's hand book
- Conduct a quick quiz to test the participants understanding and move to the next section

#### Demonstrate

- How to plan an outage via role play.

## 4.3.7: Spare Management Process

### Do

- Welcome and greet the participants. Revise the learning of the previous sessions and ask them if they have any doubts on planning the outage.

### Say

- In this session, we would be learning how to spare management process.

### Do

- Share with the participants the management process in detail along with flowchart.

### Notes for Facilitation

- Facilitate the discussion and avoid arguments
- Discuss the various steps involved in corrective maintenance in detail
- Assign the various teams presentation topics, and ask them to present the same
- Summaries with the help of page 146 of the participant's hand book
- Conduct a quick quiz to test the participants understanding and move to the next section

### Demonstrate

- How to manage a process via role play and presentation prepared by the students.

### 4.3.8: Working Instruction - Maintenance

#### Do

- Welcome and greet the participants. Revise the learning of the previous sessions and ask them if they have any doubts.

#### Say

- In this session, we would be learning working instruction for better quality and enhanced efficiency.

#### Do

- Share the related following parameters how to function/ rout plan when you are operating o ground
- Maintenance plan and maintenance equipment of POP.

#### Demonstrate

- Demonstrate the various components/instrument used on the site visit in detail.

#### Notes for Facilitation

- Facilitate the discussion and avoid arguments
- Discuss the process in detail about the challenges faced during the process and instrument required for corrective and preventive maintenance.
- Share with the students the impact on work ethics

## Answers to exercises for PHB

### Multiple Choice Questions

1. d 2. b 3. d 4. b 5. c 6. d 7. d 8. c 9. c 10. d

### Descriptive

11. Refer Unit 4.1: Fault Notification  
Topic 4.1.1 Fault Notification

12. Refer Unit 4.1 : Fault Notification  
Topic 4.1.4 Fault Notification Process

13. Refer Unit 4.1 : Fault Notification  
Topic 4.1.4 Fault Notification Guidelines

14. Refer Unit 4.2 : Fault Localization and Restoration  
Topic 4.2.1 Fault Localization and Restoration

15. Refer Unit 4.2 : Fault Localization and Restoration  
Topic 4.2.1 Fault Localization and Restoration  
Topic 4.2.4 Preparing for Fault Rectification

16. Refer Unit 4.2: Fault Localization and Restoration  
Topic 4.2.2 Cable System Faults

17. Refer Unit 4.2: Fault Localization and Restoration  
Topic 4.2.3 Problem Identification Flow Chart

18. Refer Unit 4.2: Fault Localization and Restoration  
Topic 4.2.3 Problem Identification Flow Chart  
Topic 4.2.4 Preparing for Fault Rectification

19. Refer Unit 4.2: Fault Localization and Restoration  
Topic 4.2.4 Preparing for Fault Rectification

20. Refer Unit 4.2: Fault Localization and Restoration  
Topic 4.2.5 Steps - OFC Restoration Process

21. Refer Unit 4.2: Fault Localization and Restoration  
Topic 4.2.6 Work Instructions

22. Refer Unit 4.3: Preventive and Corrective Maintenance  
Topic 4.3 Preventive and Corrective Maintenance

23. Refer Unit 4.3: Preventive and Corrective Maintenance  
Topic 4.3.3 Corrective Maintenance Process

24. Refer Unit 4.3: Preventive and Corrective Maintenance  
Topic 4.3.5 Preventive Maintenance Process

25. Refer Unit 4.3: Preventive and Corrective Maintenance  
Topic 4.3.7 Planned Outage sub-process

26. Refer Unit 4.3: Preventive and Corrective Maintenance  
Topic 4.3.8 Spare Management Process

27. Refer Unit 4.3: Preventive and Corrective Maintenance  
Topic 4.3.6 Reporting - Preventive Maintenance Checklist

## Answers to exercises for PHB

28. Refer Unit 4.3: Preventive and Corrective Maintenance  
Topic 4.3.5 Standard Operating Procedure

29. Refer Unit 4.3: Preventive and Corrective Maintenance  
Topic 4.3.9 Work Instructions - Maintenance

30. Refer Unit 2.4: Installation of Fibre Optic Cable  
Topic 2.4.13 Reporting and documentation

31. Refer Unit 2.4: Installation of Fibre Optic Cable  
Topic 2.4.13 Reporting and documentation

32. Refer Unit 2.4: Installation of Fibre Optic Cable  
Topic 2.4.13 Reporting and documentation



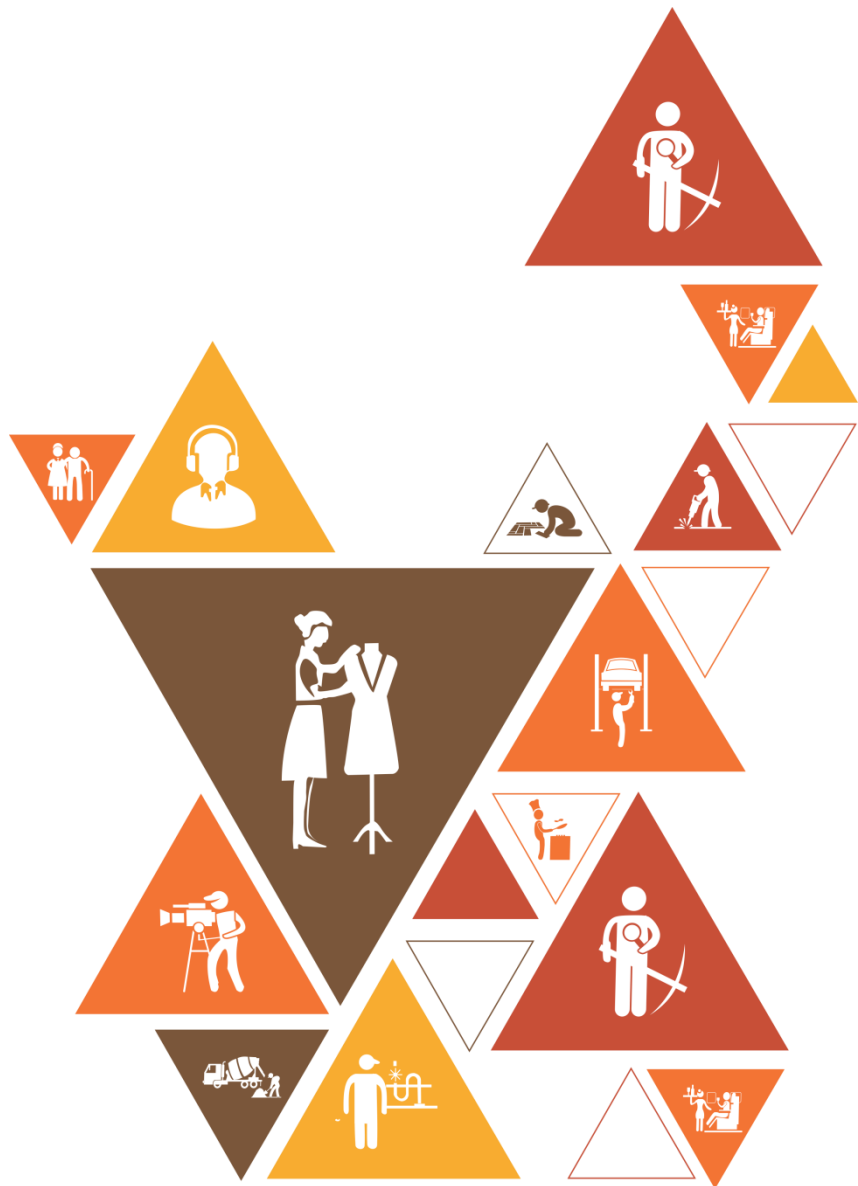



**Skill India**  
कोशल भारत - कुशल भारत



सत्यमेव जयते  
GOVERNMENT OF INDIA  
MINISTRY OF SKILL DEVELOPMENT  
& ENTREPRENEURSHIP



**N · S · D · C**  
**National**  
**Skill Development**  
**Corporation**

Transforming the skill landscape



**Telecom**  
**Sector**  
**Skill**  
**Council**

# 4. Plan work effectively Organize Resources and Implement safety Practices

Unit 4.1 – Work Place Health and Safety

Unit 4.2 – Different types of Health Hazards

Unit 4.3 - Importance of safe working Places

Unit 4.4 - Reporting Safety Hazards

Unit 4.5 - Waste Management

unit 4.6 - Organization's focus on Greening of Jobs

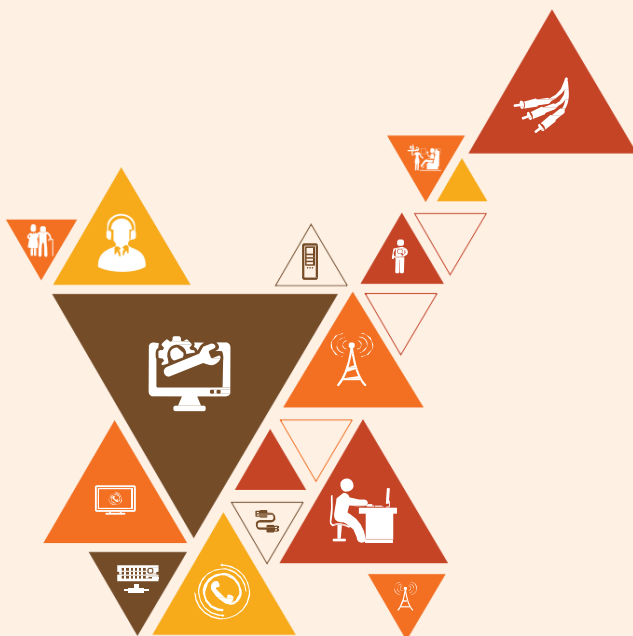

**TEL/N9101**

## Key Learning Outcomes

At the end of this module, you will be able to:

1. Explain about workplace health and safety
2. understand different types of health hazards
3. Demonstrate various first-aid techniques
4. Understand the importance of safety at workplace
5. understand basic hygiene practices and hand washing techniques
6. Explain the need for Social Distancing
7. Understand the hazard reporting methods at workplace
8. Explain e-waste and process of disposing them
9. Explain the greening of jobs

## UNIT 4.1: Workplace Health and Safety

### Unit Objectives

At the end of this unit, the participants will be able to:

1. Understand about workplace health and safety
2. Explain tips to design a safe workplace
3. Explain precautions to be taken at a workplace

### Resources to be Used

- Participant handbook, white board marker pen, notebook, whiteboard, flipchart, laptop, overhead projector, laser pointer, etc.

### Notes

- In this unit, we will discuss about workplace health & safety.

### Say

Good morning and welcome back to this training program on Telecom E-Waste Handler. In this session, we will discuss about workplace health & safety practices.

### Ask

Ask the trainees the following questions:

- What do you understand by workplace safety?

Write down the trainees' answers on the whiteboard/flipchart.

Draw appropriate cues from the answers and start teaching the lesson.

### Say

In this session, we will discuss the following points:

- Safety: Tips to design a safe workplace
- Non-Negotiable employee safety habits

Let us participate in an extempore activity to understand this unit better.

## Activity



- This activity will be based on individual performance.
- Provide each trainee with a printout/Xerox copy of the safety hazard report
- Now ask each of them to fill up the report individually
- After completing, collect all the forms and evaluate them
- End the session by providing constructive feedback

Activity	Duration (in mins)	Resources Used
Role-play – Safety Hazard Report	40 minutes	Participant handbook, whiteboard, notebook, laptop, pen, pencil, marker, printout/Xerox copy of safety hazard report, etc.

## Do



- Ensure that the report contains all possible hazards in the workplace, safety measures, and ways to counter the hazards if they occur
- Guide the trainees throughout the activity
- Ask the trainees if they have any questions
- Encourage other trainees in the class to answer it and encourage peer learning in the class
- Explain the consequences of not following the safety guidelines at the workplace

## UNIT 4.2: Different types of Health Hazards

### Unit Objectives

At the end of this unit, participants will be able to:

1. Understand the health hazards
2. Demonstrate First Aid Techniques

### Resources to be Used

- Participant handbook, pen, notebook, whiteboard, markers, flipchart, laptop, overhead projector, laser pointer, equipment and tools, safety signs and symbols, safety equipment

### Notes

- In this unit, we will discuss about different types of health hazards and first aid techniques

### Say

- Good morning and welcome back to this training program on Telecom E-Waste Handler. In this session, we will discuss about different types of health hazards.

### Ask

Ask the trainees the following questions:

- What is a health hazard?
- Can you name any health hazards that may occur at the workplace?

Write down the trainees' answers on the whiteboard/flipchart.

Draw appropriate cues from the answers and start teaching the lesson.

### Notes for Facilitation

Illness, injuries, and pain are part of human life. This can happen anyway. Every individual is prone to illness and injuries at anytime and anywhere.

In case of any of these, some kind of immediate medical attention or treatment is needed to reduce the discomfort, pain, and deterioration of the condition

Explain the first aid techniques for injuries due to various causes. For burns, electric shock, fracture due to accidental fall etc.

Explain the concept of CRP and give a demonstration using a video how to administer CRP for a patient suffering a heart attack.

Through a demonstration explain the use of various safety gadgets used in the workplace.

## Say



In this session, we will discuss the following points:

- First aid
  - First aid techniques
    - For burns
    - For broken bones and fractures
    - For heart attack/stroke
    - For head injury
  - Using breathing apparatus
  - Briefing and guidance for firefighters
  - Evacuation process
  - Special evacuation requirements for specially-abled persons
  - Importance of fire safety drills
- Let us participate in an activity to understand this unit better.

## Activity



- This session will be in the form of a "Show and Explain " activity.
- In this activity, bring a few PPE (relevant to the job role) to the class and demonstrates each of them - safety helmet, safety goggles, gloves, ear muff, respirator, harness, safety boots, etc.
- Now ask the trainees to identify the PPE and state their usage
- After the session, you will select a few volunteers and make them wear PPEs.
- The focus of this activity is to select and use appropriate personal protective equipment compatible with the work and compliant with relevant occupational health and safety guidelines.

Activity	Duration (in mins)	Resources Used
Practical activity - PPE	40 minutes	Participant handbook, laptop, overhead projector, internet connection, various protective equipment like safety helmet, safety goggles, gloves, ear muff, respirator, harness, safety boots, etc.

Do 

- Ensure that all trainees participate in the activity
- Share your inputs and insight to encourage the trainees and add to what they talk about

Summarize 

- Ask the participants what they have learnt so far.
- Ask if they have any questions related to what they have talked about so far.
- Close the discussion by summarizing the different health hazards and video demo of how to wear the PPE kits and first aid techniques.



## UNIT 4.3: Importance of safe working practices

### Unit Objectives

At the end of this unit, participants will be able to:

1. Explain Basic Hygiene Practices
2. Understand the importance of Social Distancing
3. Demonstrate the safe working practices

### Resources to be Used

- Participant handbook, pen, notebook, whiteboard, flipchart, markers, laptop, overhead projector, laser pointer, etc.

### Notes

- In this unit, we will discuss about the importance of safe working practices.

### Say

Good morning and welcome back to this training program on Telecom E-Waste Handler. In this session, we will discuss about the importance of safe working practices

### Ask

Ask the trainees the following questions:

- List a few personal hygiene tips that you regularly follow.
- How social distancing helps to reduce the spread of Covid 19?
- What are the various covid protocols people followed during the pandemic?

Write down the trainees' answers on the whiteboard/flipchart.

Draw appropriate cues from the answers and start teaching the lesson.

## Elaborate



In this session, we will discuss the following points:

- Basic hygiene practices
  - Personal hygiene
  - Personal hygiene practices at home
- Importance of social distancing
  - Social distancing and isolation
  - Self-quarantine
  - Disposing off the PPE kits
- Safe workplace practices
  - Supplies and Accessories in the first aid box
  - CPR

## Say



- Let us participate in a practical activity to understand this unit better.

## Notes for Facilitation



- Familiarize the trainees with the first aid box and the supplies inside it.
- Explain the importance of first aid and why is it good to know how to administer CRP for a patient who has suffered a heart attack.
- Answer all the questions/doubts raised by the trainees in the class
- Encourage other trainees to answer queries/questions and boost peer learning in the class

## Practical



- Gather all the trainees in the laboratory and divide them into groups of two
- Ask each group to demonstrate the correct process for performing CRP
- Ensure the students follow all the steps of CPR in the correct sequence
- This activity can also be performed on a dummy, if available

Activity	Duration (in mins)	Resources Used
Practical activity - CPR	60 minutes	Participant handbook, whiteboard, notebook, laptop, pen, marker, dummy (if available), etc.

## Do



- Prepare in advance and use appropriate energisers
- Encourage the students to explore how the training session can help them improve their work
- Keep the ambience constructive and positive
- Ensure each contribution is given fair consideration

## Exercise



1. Burnt area should be kept under cold water for a minimum of 10 minutes
2. Emergency exits should be easily accessible in case of fire
3. Antiseptic cream or Solution must be applied to the wound to reduce the skin infection
4. The RICE which is Rest, Ice, Compression and Elevation therapy must be applied to control and reduce swelling.
5. CPR is Cardio Pulmonary Resuscitation

## UNIT 4.4: Reporting Safety Hazards

### Unit Objectives

At the end of this unit, participants will be able to:

1. Discuss the process of reporting in case of emergency (safety hazards)
2. Understand methods of reporting hazards

### Resources to be Used

Participant handbook, pen, notebook, whiteboard, flipchart, markers, laptop, overhead projector, laser pointer, etc.

### Say

Good morning and welcome to this training program on Customer Care Executive (Repair Centre) In this session, we will discuss about reporting safety hazards.

### Ask

Ask the trainees the following questions:

- What is a safety hazard?

Write down the trainees' answers on the whiteboard/flipchart.

Draw appropriate cues from the answers and start teaching the lesson.

### Elaborate

In this session, we will discuss the following points:

- Methods of reporting safety hazards
- Describing hazard matrix
- Hazard report form

### Say

Let us participate in an activity to understand this unit better.

## Notes for Facilitation

- Explain the trainees about reporting the safety hazards to the people concerned.
- Explain the 6C's of communication protocols followed in the organizations.
  - Communicate First
  - Communicate Rightly
  - Communicate Credibly
  - Communicate Empathetically
  - Communicate to instigate appropriate action
  - Communicate to promote respect
- Explain about the Hazard report form
- Ask the trainees if they have any questions
- Encourage other trainees to take part in the activity and encourage peer learning in the class
- Discuss the exercises at the end of the chapter in the Participant Handbook and encourage them to answers.

## Activity

- Divide the class into small groups
- Conduct a quiz and ask questions related to the unit
- Display all questions on the projector screen
- Display the correct answer after all groups have got their chances of answering a given question

Activity	Duration (in mins)	Resources Used
Quiz – Interpreting Signs	40 minutes	Laptop, internet connection, overhead projector, white screen, whiteboard, markers, laser pointer

## Do

- Ask a student to maintain the scores on the whiteboard
- Jot down the crucial points on the whiteboard as the students speak
- Share your inputs and insight to encourage the students and add to what they talk about
- Ensure that all students participate in the class
- Ask a student to summarise what was discussed in the session
- Demonstrate enthusiasm for the subject matter, course and participant's work

## UNIT 4.5: Waste Management

### Unit Objectives

At the end of this unit, participants will be able to:

1. explain what is e-waste?
2. Understand the concept of waste management
3. Explain the process of recycling e-waste

### Resources to be Used

- Participant handbook, pen, notebook, whiteboard, flipchart, markers, laptop, overhead projector, laser pointer, etc.

### Say

Good morning and welcome back to this training program on Telecom Customer Care Executive (Repair Centre).

In this session, we will discuss about waste management.

### Ask

Ask the trainees the following questions:

- What do you understand by waste management?
- What are the sources of medical waste?

Write down the trainees' answers on the whiteboard/flipchart.

Draw appropriate cues from the answers and start teaching the lesson.

### Elaborate

In this session, we will discuss the following points:

- Introduction to e-waste
  - What is e-waste?
- Electronic goods/gadgets are classified under three major heads
- E-waste management process
- Recyclable and non-recyclable waste
- Colour codes of waste collecting bins
- Waste disposal methods
- Sources of waste
- Source of Pollution
- Types of Pollution – Air, Water, Soil, Noise, Light

## Say

Let us participate in an extempore activity to understand this unit better.

## Activity

- This activity will be based on individual performance.
- In this activity, you will give two topics to the trainees
- The first topic in this session will be air pollution.
- The second topic on which the trainees will prepare their extempore will be on waste disposal method.
- You will randomly pick up trainees and separate them into two groups.
- Ensure that the trainees are equal in number.
- Allot the trainees 2 minutes to prepare the topic you will give them.
- After the time is up, you will call out any trainee and ask them to speak on the topic for 5 minutes.
- The trainee, with a simple explanation but rich content, will be appreciated with accolades.

Activity	Duration (in mins)	Resources Used
Extempore	40 minutes	Participant Handbook, Whiteboard, Notebook, Pen, Pencil, Marker, etc.

## Do

- Do a de-briefing of the activity
- Conduct a doubt clarification session if needed.
- Encourage the quiet and shy trainees to open up and speak

## Notes for Facilitation

- Encourage other participants to answer it and encourage peer learning in the class
- Answer all the doubts in case any of the participants



## UNIT 4.6: Organization's focus on Greening of Jobs

### Unit Objectives

At the end of this unit, participants will be able to:

1. Understand the concept of ESG
2. Explain the different factors of ESG

### Resources to be Used

- Participant handbook, pen, notebook, whiteboard, flipchart, markers, laptop, overhead projector, laser pointer, etc.

### Say

Good morning and welcome back to this training program on Telecom Customer Care Executive (Repair Centre).

In this session, we will discuss about greening of Jobs

### Ask

Ask the trainees the following questions:

- What is ESG?

Write down the trainees' answers on the whiteboard/flipchart.

Draw appropriate cues from the answers and start teaching the lesson.

### Elaborate

In this session, we will discuss the following points:

- What is ESG?
  - ESG stands for Environmental, Social, and Governance.
  - Environmental, social, and governance (ESG) investing refers to a set of standards for a company's behaviour used by socially conscious investors to screen potential investments.
  - Investors are increasingly applying these non-financial factors as part of their analysis process to identify material risks and growth opportunities.
- Factors of ESG
  - Environmental
  - Social
  - Governance

## Say

Let us participate in a group discussion to explore the unit a little more.

## Activity

- Conduct a group discussion in the class on the factors of ESG
- Ask the participants what they have learnt from this exercise
- Ask if they have any questions related to what they have talked about so far
- Close the discussion by summarising the importance of the ESG in recent times

Activity	Duration (in mins)	Resources Used
Group Discussion	45 minutes	Participant Handbook, Whiteboard, Notebook, laptop, Pen, Pencil, Marker, microphone and speakers etc.

## Do

- Do a de-briefing of the activity
- Conduct a doubt clarification session if needed.
- Encourage the quiet and shy trainees to open up and speak
- Ensure a friendly and cordial atmosphere during the group discussion
- Give chance to each and everybody to give their opinion
- Guide the students in identifying key points

## Notes for Facilitation

- Encourage other participants to answer it and encourage peer learning in the class
- Answer all the doubts in case any of the participants
- Discuss the proper combination technique in group discussion
- Make sure everybody understood the concept of greening of Jobs

## Exercise

1. ESG stands for Environmental, Social Governance
2. Governance factors include Environment, Social, Governance
3. The three causes of air pollution are emission from the car, dust particles and factories emitting chemical dust
4. Mining waste includes chemical gases emitted from mine blasting
5. Landfill is a waste that can't be recycled or reused
6. Blue, Black and Green coloured bins are used in disposing the waste
7. Plastic cans are trashed in blue bin
8. computer parts, mobile devices and electronic appliances are considered as e-waste
9. part of e-waste is recycled and used again
10. E-waste is made up of hazardous substances like lead, mercury, toxic material and gas



**Skill India**  
कौशल भारत - कुशल भारत



सत्यमेव जयते  
GOVERNMENT OF INDIA  
MINISTRY OF SKILL DEVELOPMENT  
& ENTREPRENEURSHIP



N · S · D · C  
National  
Skill Development  
Corporation

Transforming the skill landscape



## 5. Communication & Interpersonal Skills

Unit 5.1 - Interaction with supervisors, peers and Customers

Unit 5.2 - Explain the importance of developing sensitivity towards differently abled people



TEL/N9102

## Key Learning Outcomes



**At the end of this module, you will be able to:**

1. Understand what communication is and the importance of communication in the workplace
2. Understand effective communication and how to communicate effectively for success
3. Discuss types of communication - verbal and non-verbal
4. Communicate at workplace
5. Communicate effectively with superiors
6. Communicate effectively with colleagues and customers using different modes viz face-to-face, telephonic and email communication
7. Understand the hurdles to effective communication
8. Conduct professionally at the workplace
9. Respect differences in gender and ability
10. Communicate effectively with a person with disabilities
11. Show respect for disabled people

## UNIT 5.1: Interaction with supervisor, peers and customers

### Unit Objectives

At the end of this unit, the participants will be able to:

4. Understand the importance of communication
5. Understand types of communication

### Resources to be Used

- Participant handbook, pen, notebook, whiteboard, flipchart, markers, laptop, overhead projector, laser pointer, equipment and tools

### Notes

- In this unit, we will discuss how to communicate effectively with supervisor, peers and customers

### Say

Good morning and welcome to this training program on Customer Care Executive (Repair Centre)  
In this session, we will discuss about effective communication with supervisor, peers and customers

### Ask

Ask the trainees the following questions:

- What is communication?
- What is non-verbal communication?
- What are the barriers to effective communication?

Write down the trainees' answers on the whiteboard/flipchart.

Draw appropriate cues from the answers and start teaching the lesson

## Elaborate



In this session, we will discuss the following points:

- What is communication?
- Why is communication important?
- Effective communication
  - Effective communication for success
  - Significance of clear and effective communication
- Types of communication
  - Verbal communication
  - Non-Verbal communication
    - Signs and symbols
    - Gestures and expressions
- Communication at workplace
  - Communication with supervisors
  - Communication with colleagues & customers
  - Face-to-face communication
  - Telephonic communication
  - Email communication
- Importance of timely completion of tasks
- Standard operating procedure
- Escalation matrix
  - Escalation mechanism
  - Escalation through CRM
- Escalation Issues at work
  - What does it mean to escalate an issue at work?
  - When should you escalate an issue at work?
- Hurdles for effective communication
- Professional conduct
- Respect gender differences
- Communication with a disabled person
  - Communicating with people with a hearing impairment
  - Respect People with disability
  - Safety at the workplace for people with disability
    - Responsibilities of an employer towards disabled people
- Workplace adaptations for people with disability
  - Workplace adaptations

## Say



In this session, we will discuss the following points:

Let us participate in the activity to understand all about effective communication

## Activity

### **Scenario 1:**

- This is an activity involving two. One volunteer as boss and the other as team member
- Provide the trainees with a scenario mentioned below
- You are the boss for a team of 15 members. You want to convey your displeasure regarding the performance of one of your team member. How would you convey this to him/her
- State what measures you will take to convey this matter to them.

### **Scenario 2:**

- This is an activity involving two. One volunteer as boss and the other as team member
- Provide the trainees with a scenario mentioned below
- You are the boss for a team of 15 members. You want to appreciate one of your team mate's performance. He closed a big business deal of Rs.1 cr. How would you do?
- State what measures you will take to appreciate to them.

Activity	Duration (in mins)	Resources Used
Mock activity	60 minutes	Participant handbook, whiteboard, laptop, notebook, pen, pencil, marker, etc.

## Do

- Ensure that all trainees participate in the class.
- Encourage the non-participating trainees to open up and speak.
- Do a de-briefing for this activity. You tell them, scolding is always done in private, one to one, whereas appreciation is always done in open in front of others, for them to feel happy about it and at the same time others get motivated to give their best performance.

## Notes for Facilitation

- Ask them to answer the questions given in the participant manual.
- Ensure that all the participants answer every question.
- Answer all the doubts raised by the trainees in the class
- Discuss the proper communication technique in all the class activity



## UNIT 5.2: Explain the importance of developing sensitivity towards differently abled people

### Unit Objectives

At the end of this unit, participants will be able to:

3. Communicate Effectively with person with disabilities
4. Respect people with disability, at workplace

### Resources to be Used

- Participant handbook, pen, notebook, whiteboard, markers, flipchart, laptop, overhead projector, laser pointer, equipment and tools

### Notes

- In this unit, we will discuss about how to communicate effectively with people who has disabilities

### Say

- Good morning and welcome back to this training program on Telecom Customer Care Executive (Repair Centre).
- In this session, we will discuss about how to communicate with people who are differently abled

### Ask

Ask the trainees the following questions:

- What is an effective communication?
- Have they ever got an opportunity to help/assist a disabled person?

Write down the trainees' answers on the whiteboard/flipchart.

Draw appropriate cues from the answers and start teaching the lesson

## Notes for Facilitation

A **disability** is any condition that makes it more difficult for a person to do certain tasks or interact with the people around them (socially or materially). These conditions, or defects, may be cognitive, developmental, intellectual, mental, physical, sensory, or a combination of multiple conditions

As a co-worker, one should be empathetic with them and talk to them politely and with respect. Every work place has guidelines for handling these kinds of people. And all employees need to adhere to those guidelines.

## Say

In this session, we will discuss the following points:

- What is a disability
- General tips for communication with disabled people
- Respect people with disability
- Work place safety for people with disability
- Work place adaptation by people with disability

## Do

- Ensure that all trainees have understood the purpose of this module
- Encourage them to participate in the discussion

## Summarize

- Ask the participants what they have learnt so far.
- Ask if they have any questions related to what they have talked about so far.
- Explain them how to interact with differently abled people, respect them and assist and support them to complete their work if need be.
- Learnt about effectively communicating with people who are differently abled.

Do 

Exercise Handling Strategy – The solution for the exercise is given as:

1. Adjust the tone of voice, don't be too loud
2. Make eye contact
3. Use appropriate language
4. Maintain adequate distance
5. Acknowledge, nod during interaction
6. Use appropriate non-verbal gestures to communicate with persons with disabilities

**Fill in the blanks**

1. Before sending the mail it's important to check the **grammar and spelling** of the content.
2. When you interact through phone, provide your identity details like **Name, company** and **department**
3. Add your **signature** at the bottom of your mail.
4. The Customer Care Executive is mainly responsible for handling **customer Queries**

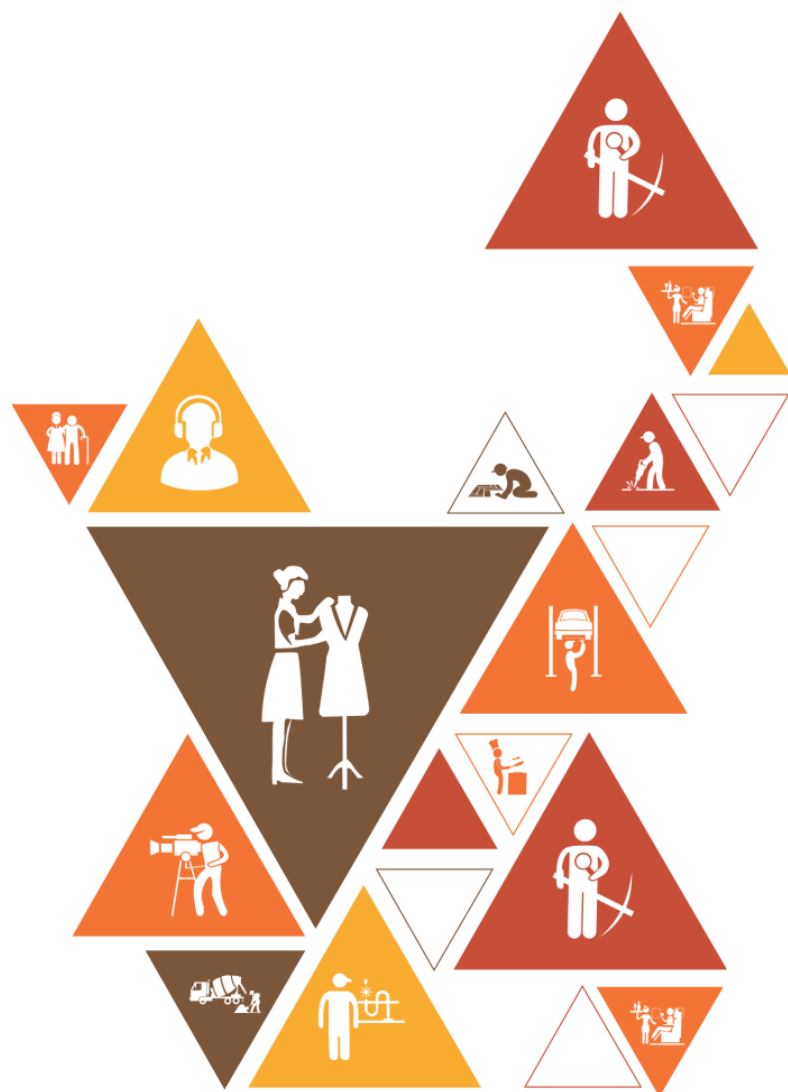



**Skill India**  
कौशल भारत - कुशल भारत



सत्यमेव जयते  
GOVERNMENT OF INDIA  
MINISTRY OF SKILL DEVELOPMENT  
& ENTREPRENEURSHIP



N · S · D · C  
National  
Skill Development  
Corporation

Transforming the skill landscape



## 8. Annexures

Annexure I: Training Delivery Plan

Annexure II: Assessment Criteria

Annexure III: List of Roles in P

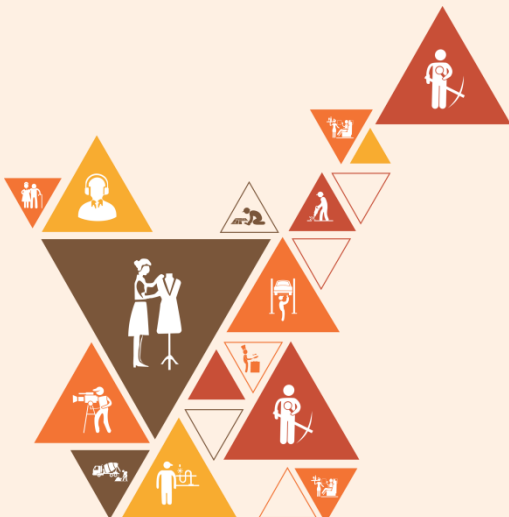

## Annexure I

### Training Delivery Plan

Training Delivery Plan			
<b>Program Name:</b>	Certificate Course in Telecom Surface Mount Technology(SMT) Technician		
<b>Qualification Pack Name &amp; Ref. ID</b>	Telecom Surface Mount Technology(SMT) Technician- TEL/Q6401		
<b>Version No.</b>	4.0	<b>Version Update Date</b>	24 / 02 / 22
<b>Pre-requisites to Training (if any)</b>	N.A		
<b>Training Outcomes</b>	<p><b>By the end of this program, the participants will be able to:</b></p> <ol style="list-style-type: none"> <li>1. Explain the evolution and growth of telecom industry</li> <li>2. Acquaint self with facets of trenching, laying, jointing and blowing of cables by: authenticating and confirming cable drum is placed near site, cable marking is as per guideline, trenching is according to the route plan</li> <li>3. Comprehend inspecting criteria of route plan, clearance, schedule and patrolling by: acquiring route plans, their clearance and check for safety of the site for cable installation</li> <li>4. Identify importance of fault maintenance, maintenance of POPs and</li> <li>5. Repairs to OFC by: compliance to enterprise policy, coordinate with NOC and carry out planned maintenance.</li> <li>6. Aggregate potential knowledge and skill to vouchsafe the importance of health and safety by: safeguard compliance of safety regulations, personal protection and environmental conditions</li> </ol>		

Sl. No.	Module Name	Session Name	Session Objectives	NOS Reference	Methodology	Training Tools / Aids	Duration
1	<b>Role and Responsibilities of an Optical Fiber Technician</b>	Brief overview of Telecom & Fiber Optics	<ul style="list-style-type: none"> <li>•Discuss the size and scope of the Telecom industry and Passive Infrastructure sub-sector</li> <li>•Identify the roles and responsibilities of an Optical Fiber Technician</li> <li>•Discuss the career progression of an Optical Fiber Technician in the Telecom industry</li> <li>•Explain the fundamentals and concept of telecommunication and the terminologies used in the work process</li> </ul>	Bridge Module	Facilitator - led discussion	Laptop, book, pen, discussion duster, Projector/ slides	T: 4 hrs. P:0hrs
2	<b>Co-ordinate Installations and Commissioning of Optical Fiber Cables</b>	Site visit and route inspection	<ul style="list-style-type: none"> <li>•Discuss how to obtain OFC route plan from the planning team or the supervisors</li> <li>•Explain to verify the proposed route to ensure that bend ratios meet manufacturer's specifications and industry standards</li> <li>•State how to develop installation work plan and identify dependencies, if any</li> <li>•Explain to determine the statutory permissions required and the relevant authorities involved</li> <li>• Discuss ways to liaise with the concerned authorities to obtain relevant clearances</li> <li>•Determine the best suited optical fiber mode (Single Mode or Multi Mode) as per the location of the project</li> </ul>	TEL/4137 PC1, PC2, PC3,PC4,PC5,PC6	Classroom lecture / PowerPoint Presentation / Question & Answer / Group Discussion	Test Equipment – Fiber Optic Power Meter, Fiber Optic Test Source, Adapters for Power Meter (Various types of optical cables), OTDR, Cable Cutter, Cable Splitter,	T: 15 hrs. P: 19hrs

		<ul style="list-style-type: none"> <li>•verify the cables are spliced as per the standard fusion/ mechanical splicing mechanisms</li> <li>•ascertain usage of proper protection material for cables such as GI (galvanised iron) pipes, RCC (reinforced cement concrete) pipes, RCC half cut pipes etc.</li> <li>• ensure use of push fit couplers as duct joints</li> <li>•confirm usage of appropriate optical connectors as per the terminating equipment requirements</li> <li>•check ducts to confirm requirement of additional protection like cover of RCC pipes, chambering and concreting based on site location and terrain</li> </ul>	TEL/4137 PC24 till PC28	Reference Test Cables	T: 15 hrs. P: 19hrs
	Choosing the right type of optic fiber cable	<ul style="list-style-type: none"> <li>•arrange tools and spares for installation</li> <li>•confirm placement of cable drum near the site location</li> <li>•test the cable on drum for optical continuity</li> <li>• ensure trenching is carried out by labor workers as per the detailed route plan requirements and site terrain</li> <li>• ensure minimum radius is maintained, where bends are necessary</li> <li>• ascertain usage of special designed dispensers to place the ducts in the trench as straight as possible</li> <li>• assess the depths of the pipe/ ducts as per the laying standards after approval from competent personnel</li> </ul>	TEL/4137 PC7, PC8, PC9,PC10,PC11, PC12,PC13,PC14		T: 15 hrs. P: 19hrs
	Tools and tool kit				



		<ul style="list-style-type: none"> <li>• verify the ducts are free from twists and collapsed portions and ensure rectification of all such portions using appropriate couplers</li> <li>• check proper uncoiling of PLB (permanently lubricated) ducts</li> <li>• examine duct joints for airtightness to ensure smooth cable blowing using cable blowing machines</li> <li>• ascertain carrying out the cable blowing/ jetting using rodder as per the standard process</li> <li>• ensure availability of additional cable length (loop) at jointing locations, for future use in case of failures</li> </ul>				
		<ul style="list-style-type: none"> <li>•confirm that the ends of the ducts are closed with end plugs to avoid ingress of mud, water or dust</li> <li>•examine that the entire length of the duct is cleaned to remove sand and dust that may damage the optical fiber cable</li> <li>• check the cables are appropriately prepared for jointing based on color and/ or sequence matching</li> <li>• determine alignment errors during splicing of optical fibers</li> <li>• assess any drop in signal due to attenuation</li> </ul>	<p>TEL/4137 PC15,PC16,PC17 ,PC18,PC19,PC10,PC21,PC22,PC23</p>			

		<ul style="list-style-type: none"> <li>•ensure completion of installation activity within the defined SLAs (Service Level Agreements)</li> <li>•monitor activities performed by the labor workers and optical splicers for timely completion of work</li> <li>• escalate instance of delay as per organization policy</li> </ul>	<p>TEL/4137 PC29,PC30,PC31</p>		
	Installation of fiber optic cable	<ul style="list-style-type: none"> <li>•determine the availability of test equipment like Optical Time Domain Reflectometer (OTDR) and power meter for carrying out optical tests</li> <li>•use appropriate colour for route and joint indicators as per the standards</li> <li>• check the splices are within quality assurance/AT standards</li> <li>• identify instances of cross fiber using power source and power meter tests and ensure their elimination</li> <li>• test the joint for transmission loss and strength and re-terminate it if the transmission loss exceeds the manufacturer specifications</li> <li>•ensure backfilling and crowning in coordination with the labour workers as per standard requirements</li> <li>• confirm placement of a stone marker at the jointing pit for identification of route and jointing pit</li> <li>•check cables markings for appropriateness as per the guidelines</li> </ul>	<p>TEL/4137 PC32 TILL PC41</p>		<p>T: 15 hrs. P: 19hrs</p>

			<ul style="list-style-type: none"> <li>•update as-build documents based on joint location and installed fiber route</li> <li>•clear site from debris and other items</li> </ul>				
			<ul style="list-style-type: none"> <li>•ensure cable id/drum numbers are recorded for future fault localization</li> <li>•document the OTDR report and summary of tests and share with appropriate teams</li> <li>•obtain sign-off from the projects team and communicate status to NOC for cable integration</li> <li>•ensure all documents available for appropriate authorities to inspect</li> </ul>	TEL/4137 PC46 TILL PC49			
3	<b>Perform planned Maintenance and Repair Activities</b>	Carry out testing of optical fiber	<ul style="list-style-type: none"> <li>•obtain as-build drawing from NOC/supervisors and identify the route assigned for maintenance of Optical Fiber Cables (OFCs)</li> <li>• ensure patrolling and surveillance of OFCs route as per the maintenance plan</li> <li>• monitor the jobs undertaken by other agencies in the vicinity of the network to ensure the safety of OFCs.</li> <li>•coordinate with authorities regarding any planned construction/activity in the vicinity of the OFCs</li> <li>• ensure sample check of as-build drawings</li> <li>•communicate any changes made to as-build drawings to the NOC/supervisors for updating the document</li> </ul>	TEL/N6403 PC1 TILL PC6	Classroom lecture / PowerPoint Presentation / Question & Answer / Group Discussion	Optical test tools (Optical Time Domain Reflectometer (OTDR), Power meter, Light meter, etc.), Sample as-build drawing, Cable Jacket Stripper, Connector Crimper	T: 20 hrs. P: 30hrs

		<ul style="list-style-type: none"> <li>•ensure availability of optical test tools like Optical Time Domain Reflectometer (OTDR), Power meter, Light meter etc.</li> <li>• check performance of OTDR and power meter tests for all the dark/spare fibers as per required periodicity</li> <li>• test end-to-end link for adherence to link budget and identify loss and reflection points</li> <li>•advise planning team for developing route strengthening workplan based on test results</li> </ul>	TEL/N6403 PC7 TILL PC10	, Fiber optic stripper, Tweezers, Cleaver, polishing puck for connectors, Polishing Plate, Black work mats, Fusion Splicer (Splicing machine), Related Standard Operating Procedures (SOPs), Format of various related reports	
	Carry out splicing of optical fiber	<ul style="list-style-type: none"> <li>•arrange outage for carrying out activity by coordinating with Network Operation Centre (NOC) prior to undertake the planned repair activities</li> <li>•ensure completion of planned repair activities within defined timelines</li> <li>•conduct optical tests on spare fibers to confirm effectiveness of the planned repair process</li> <li>•ensure taking precautions with regard to the power launched on to the fiber, in case active fibers are used for testing</li> <li>• escalate instances of delays and emergency/unresolved issues according to established organisation procedure</li> <li>•conduct periodic (monthly, quarterly, half yearly) maintenance activities</li> <li>•maintain co-located electronic equipment and ensure testing of alarms</li> </ul>	TEL/N6403 PC11 TILL PC25		T: 20 hrs. P: 30hrs

			<p>in coordination with NOC</p> <ul style="list-style-type: none"> <li>• ensure active fibers are not disturbed while testing</li> <li>• carry out planned repairs on existing joints and terminations in coordination with NCC (Network Color Code) for improvement of link margin</li> <li>• ensure raising of the tickets to the respective vendors by the NOC for the maintenance of third party elements</li> <li>• ensure completion of OFC/OTDR register with record of all fiber tests</li> <li>• maintain account of diesel oil at respective stations and ensure maintenance of assets register for sites under supervision</li> <li>• dispatch OTDR test results to supervisors for planning and monitoring of OFCs</li> <li>• ensure availability of the documents to all appropriate authorities for inspection</li> </ul>				
4	<b>Perform Corrective Maintenance Activities</b>	Fault notification	<ul style="list-style-type: none"> <li>• receive fault notifications from Network Operation Center (NOC)/supervisors</li> <li>• obtain Turn Around Time (TAT) for fault rectifications as defined in Service Level Agreements (SLAs)</li> <li>• obtain latest as-build drawing from the NOC/supervisors</li> </ul>	TEL/N6404 PC1,PC2,PC3	Classroom lecture / PowerPoint Presentation / Question & Answer / Group Discussion	Test equipment (Optical Time Domain Reflectometer (OTDR), Power meter, etc.), Related Standard Operating	T: 12 hrs. P: 16hrs
		Fault localization and restoration	<ul style="list-style-type: none"> <li>• make available test equipment (Optical Time Domain Reflectometer (OTDR), Power meter, etc.) for carrying out</li> </ul>	TEL/N6404 PC4 TILL PC15			T: 12 hrs. P: 16hrs

		<p>optical tests</p> <ul style="list-style-type: none"> <li>• identify exact fault location using OTDR tests on fiber at POP location</li> <li>• analyze as-build drawing to locate the physical site on the ground</li> <li>• coordinate excavation, pulling of appropriate cables (if feasible) and preparation of jointing pit at site through laborers</li> <li>• coordinate with the optical splicer to carry out splicing as per standard process</li> <li>• assess effectiveness of the jointing activity by reviewing OTDR and power test results</li> <li>• ensure joints are protected and strengthened appropriately using couplers, sleeves and FRPs (Fiber Reinforced Plastic) as required</li> <li>• verify if ducts require additional protection like cover of Reinforced Cement Concrete (RCC) pipes, chambering, etc. based on site location and terrain</li> <li>• coordinate back-filling of the trench through laborers and ensure rectification of network problem/fault alarms within SLA</li> <li>• monitor activities for timely completion of work by laborers and Optical Splicers</li> <li>• ensure compliance with the organisation policy while escalating unresolved faults/instances of delays</li> </ul>		<p>Procedures (SOPs), Format of various related reports</p>
--	--	---	--	---

		<p>Preventive and corrective maintenance</p>	<ul style="list-style-type: none"> <li>•ensure appropriate cable marking and route marker for direction and route identification</li> <li>•prepare jointing record for future reference</li> <li>•ensure identification of the documents to be updated</li> <li>•ascertain completion of OTDR register showing complete record of jointing tests</li> </ul>	<p>TEL/N6404 PC16,PC17,PC18 ,PC19</p>		<p>T: 12 hrs. P: 16hrs</p>
--	--	--	---	---	--	--------------------------------

## Annexure II

### Assessment Criteria

#### CRITERIA FOR ASSESSMENT OF TRAINEES

<b>Assessment Criteria for Assistant Beauty Therapist</b>	
<b>Job Role</b>	<b>Telecom Surface Mount Technology Technician</b>
<b>Qualification Pack</b>	<b>TEL/Q2501</b>
<b>Sector Skill Council</b>	<b>Telecom Sector Skill Council</b>

<b>Sr. No.</b>	<b>Guidelines for Assessment</b>
1	For assessment for each Qualification Pack will be created by the Sector Skill Council. Each Performance Criteria (PC) will be assigned marks proportional to its importance in NOS. SSC will also lay down proportion of marks for Theory and Skills Practical for each PC
2	The assessment for the theory part will be based on knowledge bank of questions created by the SSC
3	Individual assessment agencies will create unique question papers for theory part for each candidate at each examination/training centre (as per assessment criteria below)
4	Individual assessment agencies will create unique evaluations for skill practical for every student at each examination/training centre based on this criterion
5	To pass the Qualification Pack, every trainee should score a 80% overall.
6	In case of successfully passing only certain number of NOS's, the trainee is eligible to take subsequent assessment on the balance NOS's to pass the Qualification Pack.



Assessment Outcome	Assessment Criteria for Outcomes	Theory marks	Practical marks	Project marks	Viva marks
TEL/N4137 Coordinate Installation and Commissioning of Optical Fiber Cables (OFCs)	<i>Carry out inspection of route plan</i>	<b>4</b>	<b>7</b>	-	<b>5</b>
	PC1. obtain OFC route plan from the planning team or the supervisors	-	1	-	1
	PC2. verify the proposed route to ensure that bend ratios meet manufacturer's specifications and industry standards	-	2	-	1
	PC3. develop installation work plan and identify dependencies, if any	1	1	-	-
	PC4. determine the statutory permissions required and the relevant authorities involved	1	1	-	1
	PC5. liaise with the concerned authorities to obtain relevant clearances	1	1	-	1
	PC6. determine the best suited optical fiber mode (Single Mode or Multi Mode) as per the location of the project	1	1	-	1
	<i>Coordinate cable laying and pulling</i>	<b>15</b>	<b>17</b>	-	<b>5</b>
	PC7. arrange tools and spares for installation		1	-	-
	PC8. confirm placement of cable drum near the site location	1	1	-	-
	PC9. test the cable on drum for optical continuity	-	1	-	-
	PC10. ensure trenching is carried out by labor workers as per the detailed route plan requirements and site terrain	1	1	-	-
	PC11. ensure minimum radius is maintained, where bends are necessary	-	1	-	-
	PC12. ascertain usage of special designed dispensers to place the ducts in the trench as straight as possible	-	1	-	-
	PC13. assess the depths of the pipe/ ducts as per the laying standards after approval from competent personnel	-	1	-	-

PC14. verify the ducts are free from twists and collapsed portions and ensure rectification of all such portions using appropriate couplers	1	1	-	-
PC15. check proper uncoiling of PLB (permanently lubricated) ducts	-	1	-	-
PC16. examine duct joints for airtightness to ensure smooth cable blowing using cable blowing machines	1	-	-	-
PC17. ascertain carrying out the cable blowing/ jetting using rodder as per the standard process	1	-	-	-
PC18. ensure availability of additional cable length (loop) at jointing locations, for future use in case of failures	-	1	-	1
PC19. confirm that the ends of the ducts are closed with end plugs to avoid ingress of mud, water or dust	1	1	-	-
PC20. examine that the entire length of the duct is cleaned to remove sand and dust that may damage the optical fiber cable	1	-	-	-
PC21. check the cables are appropriately prepared for jointing based on color and/ or sequence matching	-	1	-	-
PC22. determine alignment errors during splicing of optical fibers	1	1	-	1
PC23. assess any drop in signal due to attenuation 1 - - 1	1	-	-	1
PC24. verify the cables are spliced as per the standard fusion/ mechanical splicing mechanisms	1	-	-	-
PC25. ascertain usage of proper protection material for cables such as GI (galvanised iron) pipes, RCC (reinforced cement concrete) pipes, RCC half cut pipes etc.	-	1	-	-
PC26. ensure use of push fit couplers as duct joints	1	-	-	-
PC27. confirm usage of appropriate optical connectors as per the terminating equipment requirements	1	-	-	-

<b>PC28.</b> check ducts to confirm requirement of additional protection like cover of RCC pipes, chambering and concreting based on site location and terrain	1	-	-	-
<b>PC29.</b> ensure completion of installation activity within the defined SLAs (Service Level Agreements)	-	1	-	-
<b>PC30.</b> monitor activities performed by the labor workers and optical splicers for timely completion of work	1	1	-	1
<b>PC31.</b> escalate instance of delay as per organization policy	1	1	-	1
<i>Test effectiveness and close the activity</i>	<b>9</b>	<b>11</b>	-	<b>5</b>
<b>PC32.</b> determine the availability of test equipment like Optical Time Domain Reflectometer (OTDR) and power meter for carrying out optical tests	1	-	-	-
<b>PC33.</b> use appropriate colour for route and joint indicators as per the standards	1	1	-	-
<b>PC34.</b> check the splices are within quality assurance/AT standards	1	1	-	-
<b>PC35.</b> identify instances of cross fiber using power source and power meter tests and ensure their elimination	1	1	-	1
<b>PC36.</b> test the joint for transmission loss and strength and re-terminate it if the transmission loss exceeds the manufacturer specifications	1	1	-	1
<b>PC37.</b> ensure backfilling and crowning in coordination with the labour workers as per standard requirements	-	1	-	1
<b>PC38.</b> confirm placement of a stone marker at the jointing pit for identification of route and jointing pit	1	1	-	1
<b>PC39.</b> check cables markings for appropriateness as per the guidelines	1	1	-	-

	PC40. update as-build documents based on joint location and installed fiber route	1	2	-	1
	PC41. clear site from debris and other items	1	2	-	-
	<i>Follow Health and Safety related to fiber operations</i>	4	5	-	4
	PC42. comply with site risk control, OHS (Occupation Health and Safety), environmental and quality and legal requirements as per organization norms	1	1	-	1
	PC43. confirm use of personal protective equipment like helmets, knee pads, safety boots, safety glasses and trench guards as per standards	1	1	-	1
	PC44. establish environmental conditions and hazards like Earth Potential Rise (EPR) while carrying out the work	1	1	-	1
	PC45. ascertain adherence to emergency plans in case of safety incidents	1	2	-	1
	<i>Report and record installation status of OFCs</i>	3	5	-	1
	PC46. ensure cable id/drum numbers are recorded for future fault localization	1	1	-	1
	PC47. document the OTDR report and summary of tests and share with appropriate teams	1	1	-	-
	PC48. obtain sign-off from the projects team and communicate status to NOC for cable integration	1	2	-	-
	PC49. ensure all documents available for appropriate authorities to inspect	-	1	-	-
	<b>NOS Total</b>	<b>35</b>	<b>45</b>	<b>-</b>	<b>20</b>
TEL/N6403 Undertake Condition based Maintenance and Planned	<i>Obtain maintenance schedule and patrol assigned route</i>	5	13	-	4
	PC1. obtain as-build drawing from NOC/supervisors and identify the route assigned for maintenance of Optical Fiber Cables (OFCs)	1	2	-	-

Repair Activities	<b>PC2.</b> ensure patrolling and surveillance of OFCs route as per the maintenance plan	1	2	-	1
	<b>PC3.</b> monitor the jobs undertaken by other agencies in the vicinity of the network to ensure the safety of OFCs.	1	3	-	1
	<b>PC4.</b> coordinate with authorities regarding any planned construction/activity in the vicinity of the OFCs	1	2	-	1
	<b>PC5.</b> ensure sample check of as-build drawings	1	2	-	1
	<b>PC6.</b> communicate any changes made to as-build drawings to the NOC/supervisors for updating the document	-	2	-	-
	<i>Carry out planned maintenance testing of dark/spare Optical Fiber Cables (OFCs)</i>	<b>5</b>	<b>10</b>	-	<b>4</b>
	<b>PC7.</b> ensure availability of optical test tools like Optical Time Domain Reflectometer (OTDR), Power meter, Light meter etc.	1	3	-	1
	<b>PC8.</b> check performance of OTDR and power meter tests for all the dark/spare fibers as per required periodicity	1	3	-	1
	<b>PC9.</b> test end-to-end link for adherence to link budget and identify loss and reflection points	1	2	-	1
	<b>PC10.</b> advise planning team for developing route strengthening workplan based on test results	2	2	-	1
	<i>Repair OFCs as per plan</i>	<b>4</b>	<b>12</b>	-	<b>4</b>
	<b>PC11.</b> arrange outage for carrying out activity by coordinating with Network Operation Centre (NOC) prior to undertake the planned repair activities	-	3	-	1
	<b>PC12.</b> ensure completion of planned repair activities within defined timelines	1	2	-	1
	<b>PC13.</b> conduct optical tests on spare fibers to confirm effectiveness of the planned repair process	1	2	-	1

PC14. ensure taking precautions with regard to the power launched on to the fiber, in case active fibers are used for testing	1	2	-	1
PC15. escalate instances of delays and emergency/unresolved issues according to established organisation procedure	1	3	-	-
<i>Carry out maintenance of equipment at Points of Presence (POPs)</i>	<b>6</b>	<b>12</b>	-	<b>4</b>
PC16. conduct periodic (monthly, quarterly, half yearly) maintenance activities	1	3	-	2
PC17. maintain co-located electronic equipment and ensure testing of alarms in coordination with NOC	1	2	-	1
PC18. ensure active fibers are not disturbed while testing	1	3	-	-
PC19. carry out planned repairs on existing joints and terminations in co-ordination with NCC (Network Color Code) for improvement of link margin	1	2	-	1
PC20. ensure raising of the tickets to the respective vendors by the NOC for the maintenance of third party elements	2	2	-	-
<i>Report to concerned authorities and record fiber test results</i>	<b>5</b>	<b>8</b>	-	<b>4</b>
PC21. ensure completion of OFC/OTDR register with record of all fiber tests	1	1	-	1
PC22. maintain account of diesel oil at respective stations	1	2	-	-
PC23. ensure maintenance of assets register for sites under supervision	1	2	-	-
PC24. dispatch OTDR test results to supervisors for planning and monitoring of OFCs	1	2	-	1
PC25. ensure availability of the documents to all appropriate authorities for inspection	1	1	-	2
<b>NOS Total</b>	<b>25</b>	<b>55</b>	-	<b>20</b>

TEL/N6404: Perform Corrective Maintenance/ Restoration of Optical Fiber Faults	<i>Handle fault notifications promptly</i>	5	5	-	-
	<b>PC1.</b> receive fault notifications from Network Operation Center (NOC)/supervisors	1	2	-	-
	<b>PC2.</b> obtain Turn Around Time (TAT) for fault rectifications as defined in Service Level Agreements (SLAs)	2	1	-	-
	<b>PC3.</b> obtain latest as-built drawing from the NOC/supervisors	2	2	-	-
	<i>Rectify the fault at POP (point of presence) location</i>	25	30	-	15
	<b>PC4.</b> make available test equipment (Optical Time Domain Reflectometer (OTDR), Power meter, etc.) for carrying out optical tests	5	5	-	4
	<b>PC5.</b> identify exact fault location using OTDR tests on fiber at POP location	5	2	-	1
	<b>PC6.</b> analyze as-built drawing to locate the physical site on the ground	1	2	-	1
	<b>PC7.</b> coordinate excavation, pulling of appropriate cables (if feasible) and preparation of jointing pit at site through laborers	2	1	-	1
	<b>PC8.</b> coordinate with the optical splicer to carry out splicing as per standard process	1	3	-	1
	<b>PC9.</b> assess effectiveness of the jointing activity by reviewing OTDR and power test results	1	3	-	1
	<b>PC10.</b> ensure joints are protected and strengthened appropriately using couplers, sleeves and FRPs (Fiber Reinforced Plastic) as required	2	2	-	1
	<b>PC11.</b> verify if ducts require additional protection like cover of Reinforced Cement Concrete (RCC) pipes, chambering, etc. based on site location and terrain	1	4	-	1
<b>PC12.</b> coordinate back-filling of the trench through laborers	2	2	-	1	

	PC13. ensure rectification of network problem/fault alarms within SLA	1	3	-	1
	PC14. monitor activities for timely completion of work by laborers and Optical Splicers	2	2	-	1
	PC15. ensure compliance with the organisation policy while escalating unresolved faults/instances of delays	2	1	-	1
	<i>Report and document the status</i>	<b>5</b>	<b>10</b>	-	<b>5</b>
	PC16. ensure appropriate cable marking and route marker for direction and route identification	1	2	-	1
	PC17. prepare jointing record for future reference	2	2	-	1
	PC18. ensure identification of the documents to be updated	1	3	-	1
	PC19. ascertain completion of OTDR register showing complete record of jointing tests	1	3	-	2
	<b>NOS Total</b>	<b>35</b>	<b>45</b>	-	<b>20</b>
TEL/N9101 Organise Work and Resources as per Health and Safety Standards	<i>Perform work as per quality standards</i>	<b>4</b>	<b>9</b>	-	<b>2</b>
	PC1. keep workspace clean and tidy	-	1	-	-
	PC2. perform individual role and responsibilities as per the job role while taking accountability for the work	1	1	-	1
	PC3. record/document tasks completed as per the requirements within specific timelines	-	1	-	1
	PC4. implement schedules to ensure timely completion of tasks	-	2	-	-
	PC5. identify the cause of a problem related to own work and validate it	2	2	-	-
	PC6. analyse problems accurately and communicate different possible solutions to the problem	1	2	-	-
	<i>Maintain safe, healthy and secure working environment</i>	<b>16</b>	<b>27</b>	-	<b>4</b>



<b>PC7.</b> comply with organisation's current health, safety, security policies and procedures	1	1	-	-
<b>PC8.</b> check for water spills in and around the work space and escalate these to the appropriate authority	1	2	-	1
<b>PC9.</b> report any identified breaches in health, safety, and security policies and procedures to the designated person	1	2	-	1
<b>PC10.</b> use safety materials such as goggles, gloves, ear plugs, caps, ESD pins, covers, shoes, etc.	1	2	-	1
<b>PC11.</b> avoid damage of components due to negligence in ESD procedures or any other loss due to safety negligence	2	3	-	1
<b>PC12.</b> identify hazards such as illness, accidents, fires or any other natural calamity safely, as per organisation's emergency procedures, within the limits of individual's authority	2	1	-	-
<b>PC13.</b> participate regularly in fire drills or other safety related workshops organised by the company	1	3	-	-
<b>PC14.</b> report any hazard outside the individual's authority to the relevant person in line with organisational procedures and warn others who may be affected	1	3	-	-
<b>PC15.</b> maintain appropriate posture while sitting/standing for long hours	1	1	-	-
<b>PC16.</b> handle heavy and hazardous materials with care, while maintaining appropriate posture	1	1	-	-
<b>PC17.</b> sanitize workstation and equipment regularly	1	2	-	-
<b>PC18.</b> clean hands with soap, alcohol-based sanitizer regularly	-	1	-	-
<b>PC19.</b> avoid contact with anyone suffering from communicable diseases and take necessary precautions	-	1	-	-

	<b>PC20.</b> take safety precautions while travelling e.g. maintain 1m distance from others, sanitize hands regularly, wear masks, etc.	1	2	-	-
	<b>PC21.</b> report hygiene and sanitation issues to appropriate authority	1	1	-	-
	<b>PC22.</b> follow recommended personal hygiene and sanitation practices, for example, washing/sanitizing hands, covering face with a bent elbow while coughing/sneezing, using PPE, etc.	1	1	-	-
	<i>Conserve material/energy/electricity</i>	<b>7</b>	<b>16</b>	-	<b>3</b>
	<b>PC23.</b> optimize usage of material including water in various tasks/activities/processes	1	2	-	-
	<b>PC24.</b> use resources such as water, electricity and others responsibly	1	2	-	1
	<b>PC25.</b> carry out routine cleaning of tools, machine and equipment	1	2	-	-
	<b>PC26.</b> optimize use of electricity/energy in various tasks/activities/processes	1	3	-	1
	<b>PC27.</b> perform periodic checks of the functioning of the equipment/machine and rectify wherever required	1	3	-	1
	<b>PC28.</b> report malfunctioning and lapses in maintenance of equipment	1	2	-	-
	<b>PC29.</b> use electrical equipment and appliances properly	1	2	-	-
	<i>Use effective waste management/recycling practices</i>	<b>3</b>	<b>8</b>	-	<b>1</b>
	<b>PC30.</b> identify recyclable, non-recyclable and hazardous waste	1	2	-	1
	<b>PC31.</b> deposit recyclable and reusable material at identified location	1	3	-	-
	<b>PC32.</b> dispose non-recyclable and hazardous waste as per recommended processes	1	3	-	-
	<b>NOS Total</b>	<b>30</b>	<b>60</b>	-	<b>10</b>
TEL/N9102 Interact	<i>Interact effectively with superiors</i>	<b>7</b>	<b>15</b>	-	<b>2</b>

Effectively with Team Members and Customers	<b>PC1.</b> receive work requirements from superiors and customers and interpret them correctly	1	2	-	-
	<b>PC2.</b> inform the supervisor and/or concerned person about any unforeseen disruptions or delays	2	4	-	1
	<b>PC3.</b> participate in decision making by providing facts and figures, giving/accepting constructive suggestions	2	5	-	1
	<b>PC4.</b> rectify errors as per feedback and ensure the errors are not repeated	2	4	-	-
	<i>Interact effectively with colleagues and customers</i>	<b>7</b>	<b>26</b>	-	<b>4</b>
	<b>PC5.</b> comply with organisation's policies and procedures for working with team members	1	2	-	-
	<b>PC6.</b> communicate professionally using appropriate mode of communication such as face-to-face, telephonic and written	2	4	-	1
	<b>PC7.</b> respond to queries and seek/provide clarifications if required	2	4	-	1
	<b>PC8.</b> co-ordinate with team to integrate work as per requirements	-	3	-	-
	<b>PC9.</b> resolve conflicts within the team/with customers to achieve smooth workflow	1	5	-	1
	<b>PC10.</b> recognize emotions accurately in self and others to build good relationships	1	4	-	-
	<b>PC11.</b> prioritize team and organization goals above personal goals	-	4	-	1
	<i>Respect differences of gender and ability</i>	<b>11</b>	<b>24</b>	-	<b>4</b>
	<b>PC12.</b> maintain a conducive environment for all the genders at the workplace	2	5	-	1
<b>PC13.</b> encourage appropriate behavior and conduct with people across gender	2	5	-	1	
<b>PC14.</b> assist team members with disability in overcoming any challenges faced in work	3	4	-	1	

<b>PC15.</b> practice appropriate verbal and non-verbal communication while interacting with People with Disability (PwD)	2	4	-	1
<b>PC16.</b> ensure equal participation of the people across genders in discussions	2	6	-	-
<b>NOS Total</b>	<b>25</b>	<b>65</b>	<b>-</b>	<b>10</b>

7	Organise resources and work effectively and safely	Perform work as per quality standards	<ul style="list-style-type: none"> <li>•Employ appropriate ways to keep the workspace clean and tidy</li> <li>•Discuss how to perform individual roles and responsibilities as per the job role while taking accountability for the work</li> <li>•Show how to record/document tasks completed as per the requirements within specific timelines</li> <li>•Perform the steps to implement schedules to ensure the timely completion of tasks</li> <li>•Identify the cause of a problem related to your own work and validate it</li> <li>•Apply appropriate techniques to analyse problems accurately and communicate different possible solutions to the problem</li> </ul>	TEL/N9101 PC1, PC2, PC3, PC4, PC5, PC6	Classroom lecture / PowerPoint Presentation / Question & Answer / Group Discussion	Whiteboard/blackboard marker /chalk, Duster, Computer or Laptop attached to LCD projector, Personal Protection Equipment: Safety glasses, Head protection, Rubber gloves, Safety footwear, Warning signs and tapes, Fire extinguisher and First aid kit	6 T(2:00) P(4:00)
8		Maintain a safe, healthy and secure working environment (Part - 1)	<ul style="list-style-type: none"> <li>•Discuss how to comply with the organisation's current health, safety, security policies and procedures</li> <li>•Demonstrate the steps to check for</li> </ul>	TEL/N9101 PC1, PC2, PC3, PC4, PC5, PC6, PC7, PC8, PC9, PC10, PC11, PC12, PC13, PC14			6 T(2:00) P(4:00)

			<p>water spills in and around the workspace and escalate these to the appropriate authority</p> <ul style="list-style-type: none"><li>•Practice reporting any identified breaches in health, safety, and security policies and procedures to the designated person</li><li>•Use safety materials such as goggles, gloves, earplugs, caps, ESD pins, covers, shoes, etc.</li><li>•Apply required precautions to avoid damage of components due to negligence in ESD procedures or any other loss due to safety negligence</li><li>•Identify hazards such as illness, accidents, fires or any other natural calamity safely, as per the organisation's emergency procedures, within the limits of the individual's authority</li><li>•Explain the importance of regularly participating in fire drills or other safety-related workshops organised by the company</li><li>•Discuss the significance of reporting any hazard outside the individual's authority to the relevant person in line with organisational procedures and warn others who may be affected</li></ul>			
--	--	--	--	--	--	--



9		Maintain a safe, healthy and secure working environment (Part - 2)	<ul style="list-style-type: none"> <li>• Explain how to maintain appropriate posture while sitting/standing for long hours</li> <li>• Employ appropriate techniques to handle heavy and hazardous materials with care while maintaining an appropriate posture</li> <li>• Discuss the importance of sanitising workstations and equipment regularly</li> <li>• Discuss how to avoid contact with anyone suffering from communicable diseases and take necessary precautions</li> <li>• Show how to clean hands with soap and alcohol-based sanitiser regularly</li> <li>• List the safety precautions to be taken while travelling, e.g., maintain a 1m distance from others, sanitise hands regularly, wear masks, etc.</li> <li>• Role-play a situation to report hygiene and sanitation issues to the appropriate authority</li> <li>• Discuss how to follow recommended personal hygiene and sanitation practices, for example, washing/sanitising hands, covering the face with a bent elbow while coughing/sneezing, using PPE, etc.</li> </ul>	TEL/N9101 PC15, PC16, PC17, PC18, PC19, PC20, PC21, PC22			6 T(2:00) P(4:00)
---	--	--	---	---	--	--	-------------------------

10		Conserve material / energy / electricity	<ul style="list-style-type: none"> <li>•Apply appropriate ways to optimise the usage of material, including water, in various tasks/activities/proc esses</li> <li>•Use resources such as water, electricity and others responsibly</li> <li>•Demonstrate the steps to carry out routine cleaning of tools, machines and equipment</li> <li>• Apply appropriate ways to optimise the use of electricity/energy in various tasks/activities/proc esses</li> <li>•Perform periodic checks of the functioning of the equipment/machine and rectify wherever required</li> <li>•Explain the significance of reporting malfunctioning and lapses in the maintenance of equipment</li> <li>•Use electrical equipment and appliances properly</li> </ul>	TEL/N9101 PC23, PC24, PC25, PC26, PC27, PC28, PC29			6 T(2:00) P(4:00)
11		Use effective waste management / recycling practices	<ul style="list-style-type: none"> <li>•Identify recyclable, non-recyclable and hazardous waste</li> <li>•Apply appropriate ways to deposit recyclable and reusable material at the identified location</li> <li>•Explain the process to dispose of non-recyclable and hazardous waste as per recommended processes</li> </ul>	TEL/N9101 PC30, PC31, PC32			6 T(2:00) P(4:00)











12	Communication and interpersonal skills	Interact effectively with superiors	<ul style="list-style-type: none"> <li>• Explain how to receive work requirements from superiors and customers and interpret them correctly</li> <li>• Role-play a situation to inform the supervisor and/or concerned person about any unforeseen disruptions or delays</li> <li>• Practice participating in decision-making by providing facts and figures, giving/accepting constructive suggestions</li> <li>• Practice rectifying errors as per feedback and ensure the errors are not repeated</li> </ul>	TEL/N9102 PC1, PC2, PC3, PC4	Classroom lecture / PowerPoint Presentation / Question & Answer / Group Discussion	Whiteboard and Markers, Chart paper and sketch pens, LCD Projector and Laptop for presentations, Sample of escalation matrix, organisation structure	6 T(2:00) P(4:00)
13		Interact effectively with colleagues and customers (Part - 1)	<ul style="list-style-type: none"> <li>• Discuss how to comply with the organisation's policies and procedures for working with team members</li> <li>• Apply appropriate modes of communication, such as face-to-face, telephonic and written, to communicate professionally</li> <li>• Show how to respond to queries and seek/provide clarifications if required</li> </ul>	TEL/N9102 PC5, PC6, PC7			6 T(2:00) P(4:00)
14		Interact effectively with colleagues and customers (Part - 2)	<ul style="list-style-type: none"> <li>• Illustrate the process to co-ordinate with the team to integrate work as per requirements</li> <li>• Discuss how to resolve conflicts within the team/with customers to achieve a smooth workflow</li> <li>• Discuss how to recognise emotions accurately in self</li> </ul>	TEL/N9102 PC8, PC9, PC10, PC11			6 T(2:00) P(4:00)



			and others to build good relationships •State how to prioritise team and organisation goals above personal goals			
15		Gender sensitisation	•Explain how to maintain a conducive environment for all genders in the workplace •Discuss ways to encourage appropriate behaviour and conduct with people across gender •Explain how to ensure equal participation of people across genders in discussions	TEL/N9102 PC12, PC13, PC16		6 T(2:00) P(4:00)
16		PwD sensitisation	•Identify ways to assist team members with a disability in overcoming any challenges faced at work •Practice appropriate verbal and non-verbal communication while interacting with People with Disability (PwD)	TEL/N9102 PC14, PC15		6 T(2:00) P(4:00)
17	Employability Skills	DGT/VSQ/N0102 Employability Skills		DGT/VSQ/N0101		60 hrs
<b>Total Duration</b>						<b>Theory Duration 170 Practical Duration 230</b>
<b>On the Job Training (OJT)</b>						<b>100</b>
<b>Employability Skills (DGT/VSQ/N0104) (<a href="https://eskillindia.org/NewEmployability">https://eskillindia.org/NewEmployability</a>)</b>						<b>60</b>
<b>Total Duration (Theory + Practical + ES)</b>						<b>560</b>

Do 

- Explain each Guideline for Assessment in detail
- Explain the score that each trainee needs to obtain
- Recapitulate each NOS one-by-one and take participants through the allocation of marks for Theory and Skills Practical.
- Explain the Allocation of Marks. Explain that they will be assessed on Theory and Skills Practical.
- Explain that for the first NOS, 179 marks are allotted for Theory and 121 for Skills Practical.

## Annexure

Chapter No.	Unit No.	Topic Name	Page No.	QR Code
2	2.4	10 tips for installing fiber optic cables	<a href="#">52</a>	 Click/Scan the QR code to access the related video
1	1.1	What is Fiber-Optic Cable with Full Information	<a href="#">17</a>	 Click/Scan the QR code to access the related video
2	2.3	Fiber Optic cable splicing (in Hindi)	<a href="#">37</a>	 Click/Scan the QR code to access the related video
2	2.2	Optical fiber cables, how do they work?	<a href="#">29</a>	 Click/Scan the QR code to access the related video
6	6.2	First Aid Techniques	<a href="#">162</a>	 Click/Scan the QR code to access the related video
5	5.3	Handwashing Techniques	<a href="#">170</a>	 Click/Scan the QR code to access the related video
6	6.3	CPR	<a href="#">174</a>	 Click/Scan the QR code to access the related video
6	6.5	E-waste Management Process	<a href="#">179</a>	 Click/Scan the QR code to access the related video
5	5.1	Types of Communication	<a href="#">189</a>	 Click/Scan the QR code to access the related video

Chapter No.	Unit No.	Topic Name	Page No.	QR Code
5	5.1	Communication with Colleagues and Customers	<a href="#">191</a>	 Click/Scan the QR code to access the related video
5	5.1	Telephone Communication	<a href="#">193</a>	 Click/Scan the QR code to access the related video
<b>Employability Skills</b>				 Click/Scan the QR code to access the related video



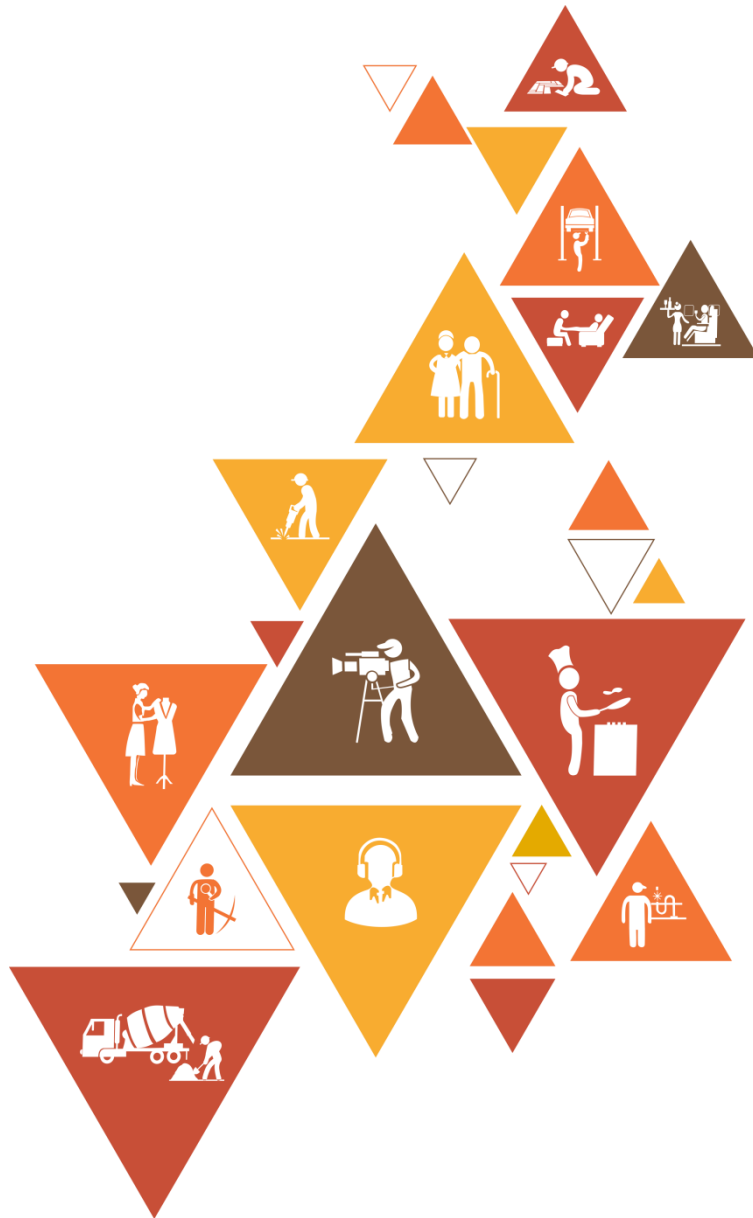



**Skill India**  
कौशल भारत - कुशल भारत



सत्यमेव जयते  
GOVERNMENT OF INDIA  
MINISTRY OF SKILL DEVELOPMENT  
& ENTREPRENEURSHIP



N.S.D.C.  
National  
Skill Development  
Corporation  
Transforming the skill landscape



**Telecom  
Sector  
Skill  
Council**



Click/Scan the QR code to access e-Book

Address : 2nd Floor, Plot No 105, Sector 44, Gurgaon 122003

Email : [tssc@tsscindia.com](mailto:tssc@tsscindia.com)

Website : [www.tsscindia.com](http://www.tsscindia.com)

Phone : +91-124-4148029, 4375891

CIN No : 00000000

Price: ₹